

RITTAL GmbH & Co. KG

Auf dem Stuetzelberg
D – 35745 Herborn
Germany.

E Mail: info@rittal.de
http://www.rittal.de
Tel. : (+49) - (0)2772 / 505 - 0
Fax : (+49) - (0)2772 / 505 - 2319



Installation and Operating Instructions

FAS Fan Alarm System

DK 7320.811

- 01. September 2003 -

We reserve all rights for this technical documentation. It may neither be reproduced nor made available to third parties without our prior consent. It may also in any other way not be utilised improperly by the recipient or third parties. Non-compliance involves payment of damages and may result in criminal liability.

II Table of contents

	Page
I Front page	1
II Table of contents	2
0. Introduction	3
1. Service und Service address	4
2. FAS - Fan Alarm System	5
2.1 Description	5
3. Installation	6
3.1 Mechanical Components	6
3.2 Electrical Components	6
4. Commencing Operation	7
5. Operation	7
6. Maintenance	8
7. Cleaning	8
8. Disposal	8
<u>Appendix</u>	
A 1 Scope of supply/Accessories - Fan Alarm System	9
B 1 Technical Data - Fan Alarm System	10
C 1 Functional diagram	11
D 1 Installation Instructions – Fan Alarm System	12
D 2 Installation Instructions – Single Mounting Unit	13
D 3 Installation Instructions – 1 U Mounting Unit	14
E 1 Electrical Connection - Fan Alarm System	15
F 1 Checklist Commencing Operation - Fan Alarm System	17
G 1 Display and operating elements at enclosure.	18



0. Safety advice

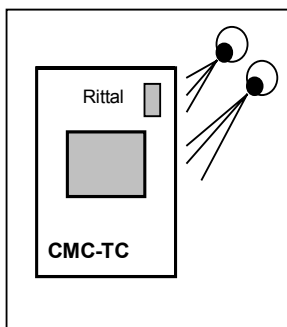

General notes

The installation and operating instructions are containing basic information for installation, for putting into operation, and for operating the RITTAL FAS. It is a must to make the instructions available to the installation technician and the administrative operating personnel and that they should read these carefully. RITTAL cannot accept liability for personal injury and material damage resulting from nonobservance of the safety advice in the installation and operating instructions. **It is essential to observe not only the general safety advice given in this chapter, but also the special safety advice given in the other chapters.**

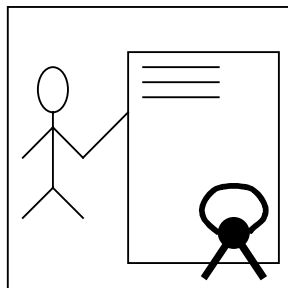

Personnel qualification and authorisation

Operation and any changes may be carried out only be authorised specialist personnel or by authorised trained operating personnel.

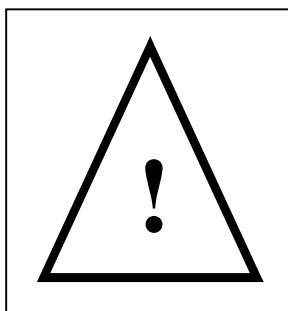

Risks due to non-observance of safety advice

Nonobservance of the safety advice may result in risks for the personnel, as well as to the RITTAL FAS together with the connected consumers. Nonobservance of the safety advice is involving loss of the right to claim for all and any damages.

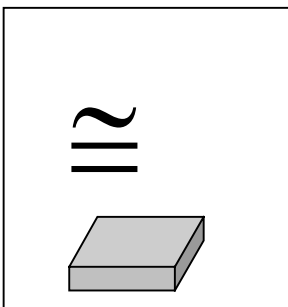

Working at the Fan Alarm System

The general applicable electrical regulations of the country in which the unit is installed and operated must be observed, just as the existing national regulations for the prevention of accidents and possibly existing internal rules (work, operating, safety regulations) of the operator. Prior to working at the unit this must be disconnected from the supply and secured against reclosing.

Original accessories and accessories authorised by the manufacturer ensure safety. The use of other parts may make void the liability for consequences resulting from this. Repairs to the FAS must only be conducted by Rittal or authorised, trained staff.

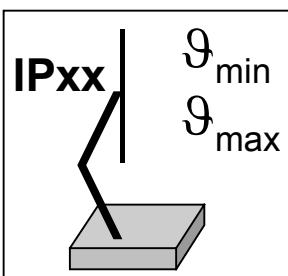

Operating reliability

The operating reliability of the unit supplied is only warranted in case of use as intended and according to the rules. The limit values quoted in the technical data (see Appendix **B Technical data**) must not be exceeded under any conditions. This applies particularly to the allowed ambient temperature range and the allowed IP protection category. For applications with a higher specified IP protection category the Rittal FAS must be installed in an enclosure of a higher IP protection category, complying with the specified protection category. Direct contact with water, aggressive media and inflammable gases or vapours is strictly prohibited.



1. Service and service address

Rittal is always prepared to provide service and assistance on technical and other matters concerning the product range. You can contact us also by e-mail to the address given below.

RITTAL GmbH & Co. KG
PM IT-Service
Auf dem Stuetzelberg

D-35745 Herborn
Germany

<http://www.rittal.de>

eMail: info@rittal.de Attention: Please quote always the article numbers in the reference line!

Tel.: +49 (0)2772/505-0
Fax: +49 (0)2772/505-2319

Further information and the updated operating instructions for the RITTAL FAS are ready for downloading from the Rittal homepage.



2. FAS – Fan Alarm System

2.1 Description

The RITTAL FAS is a revolution monitoring fan system that is operated with 24 V DC or optionally with 48 V DC. The system is designed with the concept of Plug & Play-technology. The supervision of revolutions of upto 6 Fans can be achieved with the Alarm System. As soon as one or several ventilators fall out, the FAS recognizes the situation and alarms independent the condition. The alarm identification process is carried out via a integrated collective fault signal through a potential free relay switching circuit, optically per incorporated LED and acoustically per incorporated beeper.

Optionally the FAS can be bound at the enclosure monitoring system CMC-TC over the enclosed RJ12-Cable at a free Port of the I/O Unit. In connection with the CMC-TC I/O Unit, the FAS behaves similar to a sensor unit.

Further references regarding the working of the FAS system can be taken from the CMC-TC mounting and-operating-instructions to the Processing Unit DK 7320.100.

The FAS-fans are predesigned for the installation into the RITTAL roof fan plates. The FAS can be secured by means of the enclosed strap each on the side of the side wall or on devices fastened within the enclosures. The 19“- reinforcement can be achieved by means of the Installation unit 1 HE (DK 7320.440), the installation can be also on the enclosure rails with the use of the single installation module (DK 7320.450).



3. Installation.

The user is free to decide on the location in a cabinet system or a wall housing system of the RITTAL FAS. The length of lines should not exceed the lengths specified in the Technical data for preventing losses caused by unnecessary line lengths. In addition, the allowed ambient temperature and humidity ranges must be complied with, just as the IP protection category as required for the specific application. The appropriate information is given in Appendix **B Technical data**. Compliance with a higher required IP protection category can be achieved by installation into a enclosure or enclosure system having the required protection category, whereby the air supply may not be cut off.

In addition, the following points must be observed:

- When using accessories in connection with the RITTAL FAS, the **installation and operating instructions for the accessories** and for the RITTAL FAS must be observed.
- Repair work on the FAS may be carried out only by authorised specialist personnel.
- In the event of modifications to or inside the enclosure (such as the installation of new FAS monitoring components), it is essential that the Rittal operating manual is observed.

3.1 Mechanical components

Note: The RITTAL FAS can be mounted optionally on the inside side panel, to the enclosure frame, case, or on the shelf board, in the front or rear 19" level, or sideways next to the 19" level using optionally single or standard mounting brackets.

See **Appendix D Installation instructions**

3.2 Electrical components

Note: During installation the existing national regulations of the country, in which the RITTAL CMC is to be installed and operated, must be observed!

- After the complete installation of the FAS including the fan and covers of the fan system the FAS can be put into operation, injury danger with the intialization of the fan units could exist.

In addition the following points must be observed:

- Existing safety devices must not be made ineffective.
- The electric supply voltage and frequency must correspond to the rated values given on the rear side of the device and in Appendix **B Technical Data**.
- Prior to working on the RITTAL FAS this must be made voltage-free and secured against reclosing.
- Cable clamping and protection is made by means of commercial cable ties at the casing or enclosure that is used.



See Appendix **E 1 Electrical Connection - Fan Alarm System**

4. Commencing operation

Note: The RITTAL FCS is an independent system without mains switch loading that starts independently when the mains voltage is connected.

Please, follow the steps given in Appendix F 1 Check list Commencing operation of FAS.

See Appendix **F 1 Check list Commencing operation Fan Alarm System.**

5. Operation

See Appendix **G 1 Display and operating elements.**

The operation of the RITTAL FAS takes place via the Escape button C (Clear) on the front panel. There are two system conditions, where one could press the button C:

1. To acknowledge the Alarm from by the FAS unit, wherein the acoustic beeper is reset. The beeper is disengaged but the alarm relay remains on.
2. To confirm over the change in the configuration and to simultaneously query the new configuration. This takes place via pressing of the key C for at least 3 seconds.

Note:

When there are no fans connected to the FAS, there is no alarm.

6. Maintenance

The RITTAL FAS is maintenance-free and does not have to be opened for installation or operation. The opening of the case is thus prohibited and will result in any warranty and liability claims being voided!

7. Cleaning

You can clean the RITTAL FAS-System with a wet drape. It isn't allowed to use aggressive cleaning agent, like petroleum ether, acids, etc. The aggressive agents destroy the RITTAL FAS-System.

8. Disposal

Because the FAS consists mainly of the components housing and the printed circuit board, the device (if no longer required) has to be brought to the disposal of the electronics utilization.



A 1 Scope of supply / Accessories- Fan Alarm System

DK 7320.811

Scope of supply

- Item. 1: one Fan Alarm System
 Item. 2: Self-adhesive Velcro tape (90 mm x 16 mm) for fastening
 Item. 3: 1 commutation cable (RJ 12) for connecting into CMC-TC-System, 2 m
 Item. 4: Operation and mounting instructions Manual German/English **A30949 00 IT 74**
 Item. 5: Packaging

Accessories

Accessories	Designation	P.of	required	Mod-Nr. DK
Power Supply	Power connection line FAS	1 .	Yes, depending on power supply	7320.813
	CMC-TC Netzteil 24 V, 3 A 100-240 V AC, IEC, UL-approval	1 .		7320.425
	CMC-TC Power Pack 24 V, 48 V DC large Input (terminal strip)	1 .		7320.435
Connection cable Power pack	Connection cable IEC connector Country version D	1 .	Yes after chosen power supply 1x for the power pack 7320.425	7200.210
	Connection cable IEC connector Country version GB	1 .		7200.211
	Connection cable IEC connector Country version F/B	1 .		7200.210
	Connection cable IEC connector Country version CH	1 .		7200.213
	Connection cable IEC connector Country version USA/CDN, UL-approval FT1	1 .		7200.214
	Extension cable IEC connector and socket	1 .		7200.215
Fan with revolution monitoring	Fan 24 V DC with integrated revolution monitoring system	2 .	Yes Fan port once, however max. 6 pcs. of the same Type !	7320.812
	Fan 48 V DC with integrated revolution monitoring system	2 .		On request
Installation	1 U Mounting unit	1.	Yes, after place of fastening	7320.440
	1 U Single-mounting-unit with strain relief	1.		7320.450
CMC-TC Coupling	CMC-TC Processing Unit	1.	max. four FAS-Systems with one I/O-Unit	7320.100
	CMC-TC I/O – Unit	1 .		7320.210
	Connection cable Cat5 0,5m (I/O - PU)	4 .		7320.470

Reference: the RITTAL FAS can be operated independently or in connection with the CMC-TC system .In each case, a separate power supply is required for the FAS.



B 1 Technical Data – Fan Alarm System

DK 7320.811

Enclosure	Plastic covering with metal trim
Height	1 U, approx. 4.45 cm
Width	approx. 13.6 cm
Depth	approx. 12.9 cm
Weight	approx. 0.35 kg without packaging
Potential equalisation	Not required, due to safety extra-low voltage 24 V, DC
Earthing	Not required, due to safety extra-low voltage 24 V, DC
IP Protection category	IP 20 per EN 60529
Keys	1 Membrane key, acknowledgement key (quit)
LED	1x, (Active/Alarm)
acoustic signal	1x, Piezo-beeper
Temp. application range	+ 5 °C to 45 °C/+ 41 °F to 113 °F
Humidity application range	+ 5 % - 95 % relative humidity, no condensation
Storage temperature range	-20 °C to 60 °C/ - 4 °F to 140 °F
Power connection:	
Power supply	1x, DC 24 V or DC 48V, max. current 3 A
Current protection	Fine fuse: T 2 A, UL-approval
Maximum Line length ...	
... FAS to I/O Unit:	12 m
Output Alarm relays	1x, RJ 12-sockets, shielded
Type of relay	Potential-free change-over contact
Max. current consumption	100 mA with internal or 1 A with external power connection
Max. voltage	DC, 24 V/48 V intern or 60 V with external power connection

C 1 Functional Diagram

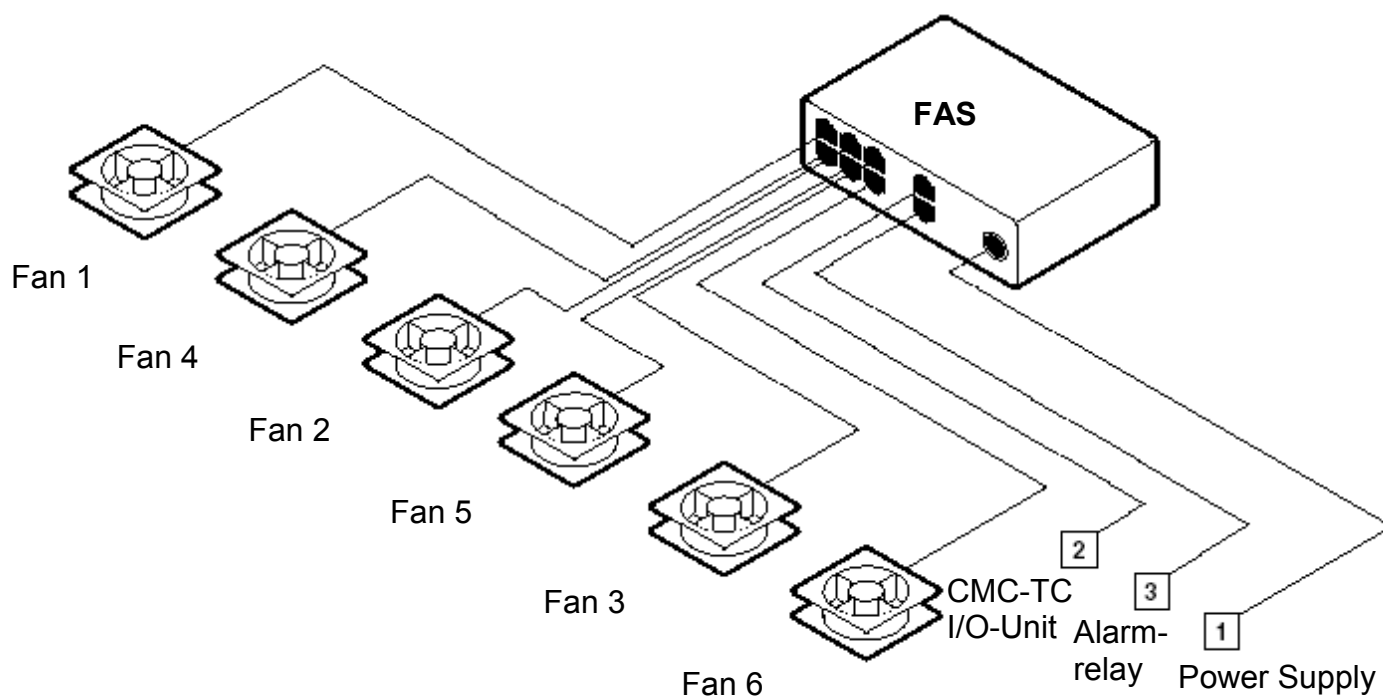

D 1 Installation Instructions – Fan Alarm System

DK 7320.811

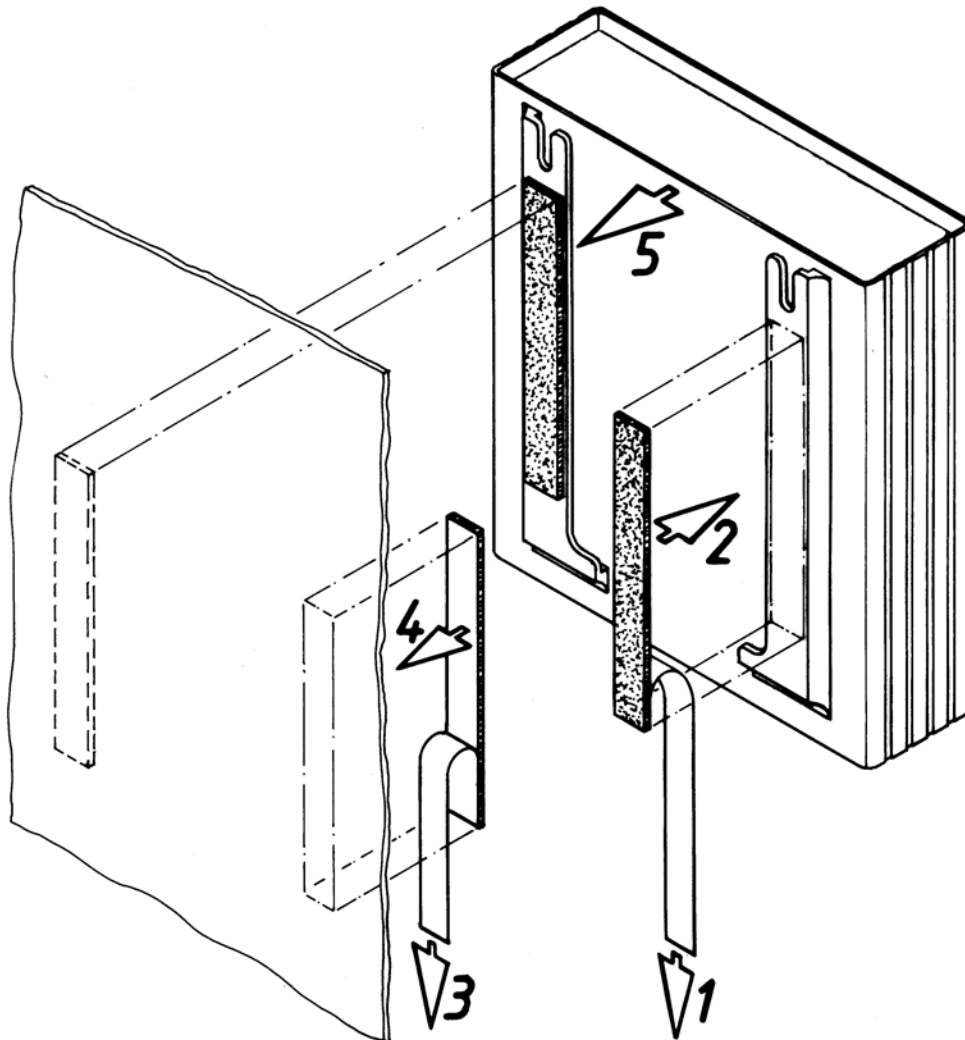
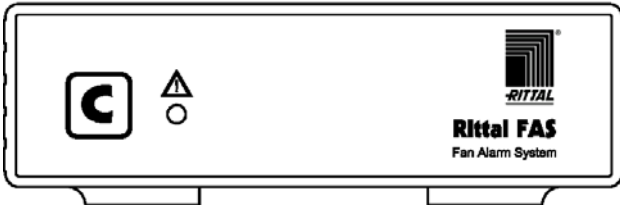
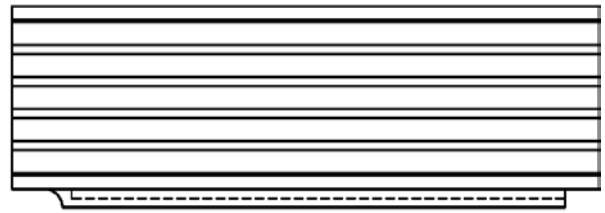
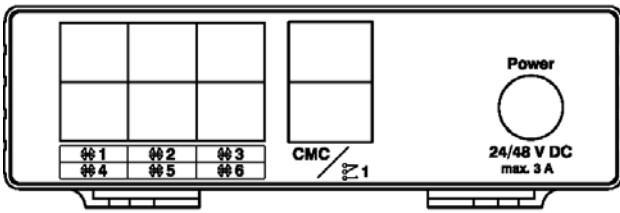

D 2 Installation Instructions- Single Mounting Unit

DK 7320.450

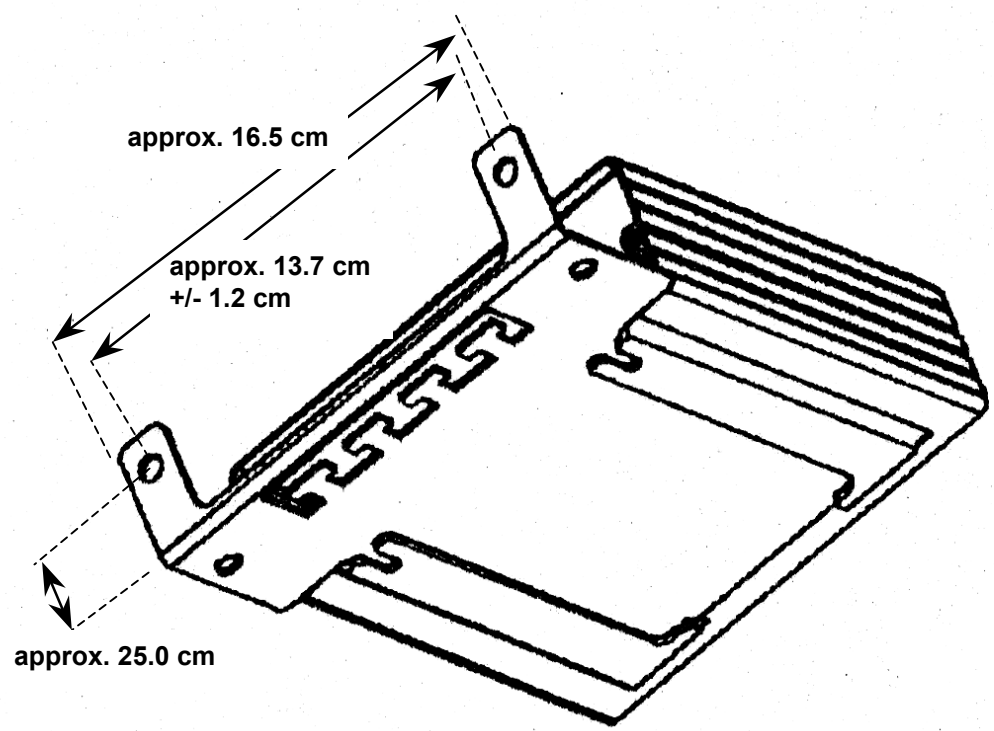
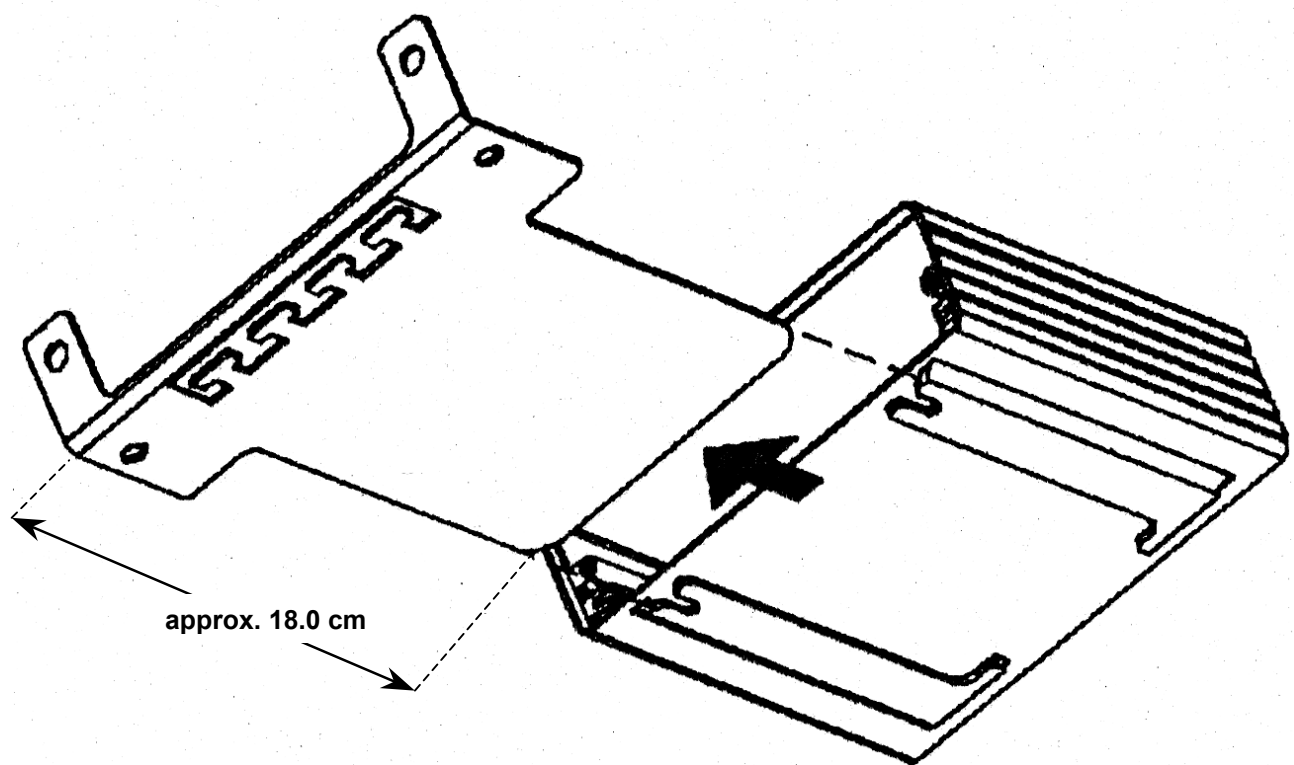

D 3 Installation Instructions - 1 U Mounting Unit

DK 7320.440

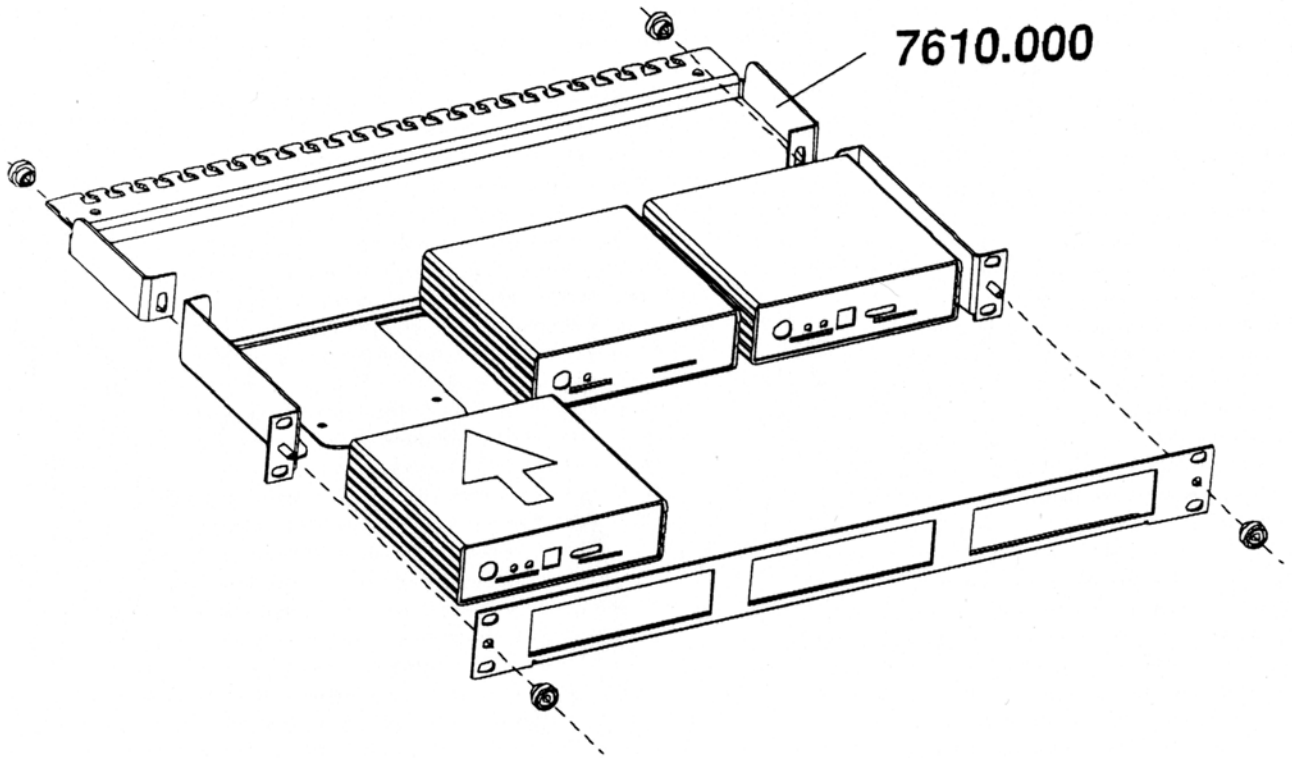

FAS or CMC-TC Units

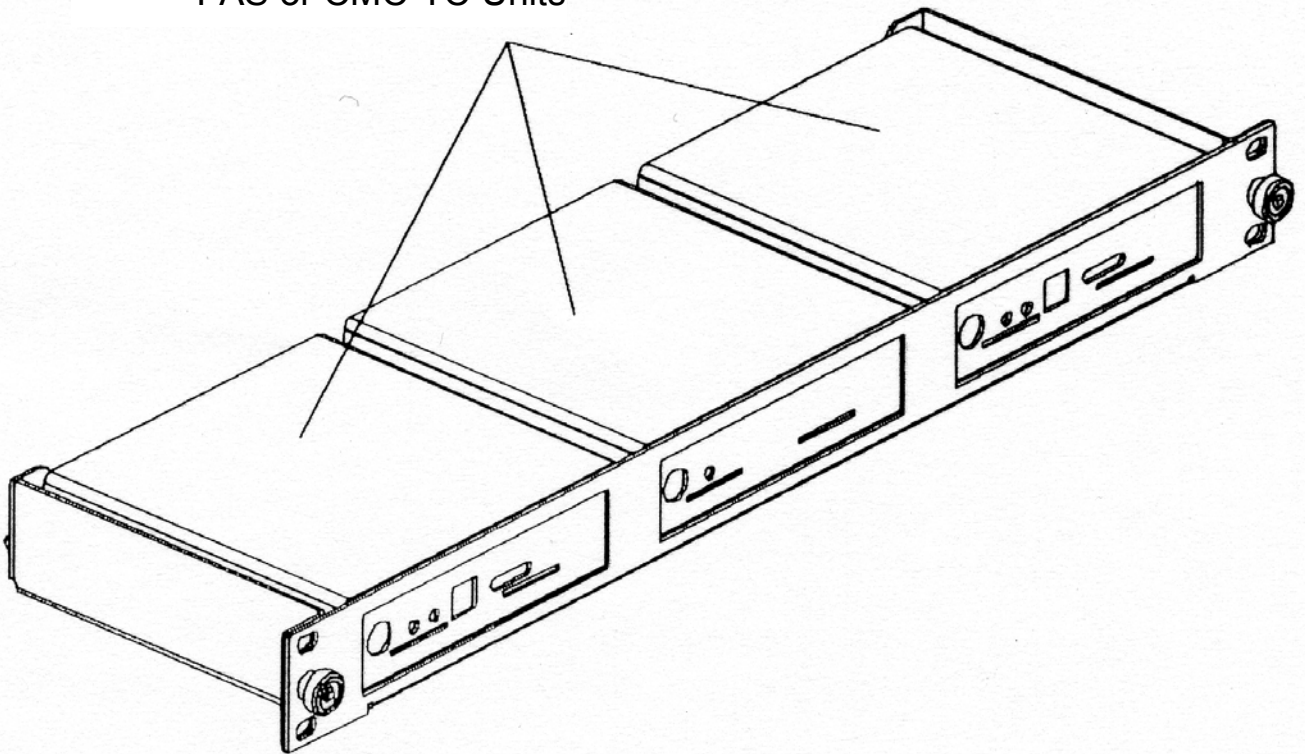

E 1 Electrical Connections: Fan Alarm System

Attention: Before execution of the electric connections of the RITTAL fan alarm system the references in the chapter 3.2 electric components are to be noted unconditionally.

1. Power Supply

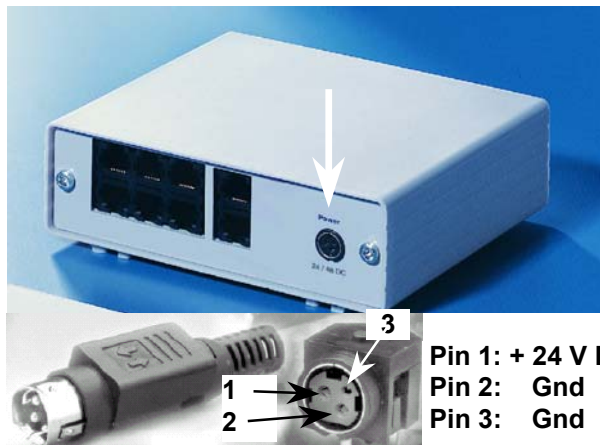

The power supply of the FAS is provided through as in the supplement **A1 Delivery/accessories** selectively with DC 24 V or DC 48 V. The networks components are exclusively for the powersupply of the CMC-TC or to use FAS/FCS !

The connector of the network component is connected at the socket power of the FAS. At the same time the designation arrow on the bushings label shows Power. The connector races independently. The alarm LED illuminates green as soon as the Unit is powered. The operation power supply is supplied as along as there is a provision to the fan.

2. Connection of the fan.



The Fan (see Appendix A1 Delivery / Accessories) are to be selected corresponding to the power supply thru the mains. A 24V-Fan may not exchanged for a 42 V Fan based on the power supply. Otherwise the FAS and/or the fan will be destroyed. The connection lines of the fans are put away into the left of positioned RJ 12-bushings. At maximum 6 ventilators can be connected.

3. Connection to the I/O Unit



The FAS is connected by means of the enclosed RJ 12-cable to the CMC-TC I/O Unit (DK 7320.210). For the operating of the FAS at the CMC-TC, it is required that the Processing Unit of the CMC-TC system has the SW-version 1.20 or higher



E 1 Electrical Connections: Fan Alarm System

DK 7320.811

4. Connection alarm relays (potential free change over contacts)



The alarm relay is connected through the RJ 12 sockets using RJ 12 connectors. The technical specification of the alarm relay is shown in **Appendix B1 Technical data**, which you must not exceed for technical and safety-relevant reasons. The assignment of the alarm relay is made by software parameterisation, see **Appendix G Display and operation CMC-TC by browser**. The internal circuitry of the alarm relay is shown below.

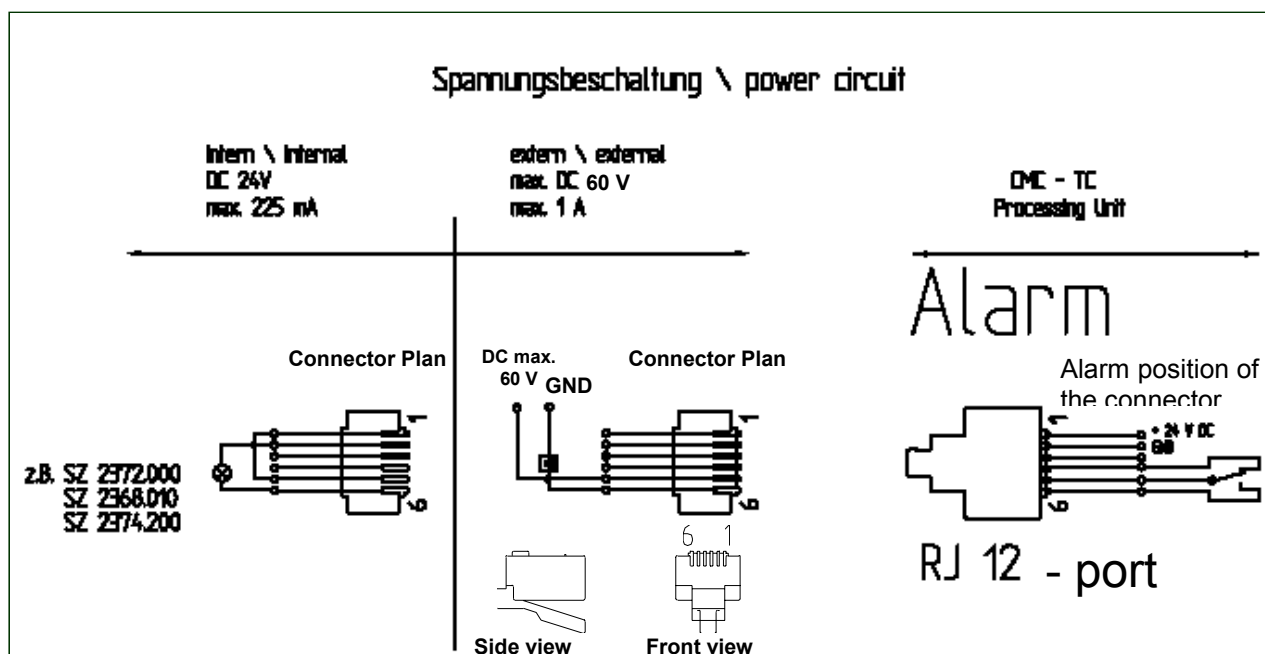

Status	Alarm LED	Relay
Normal condition	green	tightened / energized, Pin5 onto Pin6 switched
Alarm: Fan defect	red	Broken down, Pin5 onto Pin4 switched
Alarm: Configuration defect	red/orange/green	Broken down, Pin5 onto Pin4 switched
FAS No power supply	off	Broken down, Pin5 onto Pin4 switched

F 1 Checklist start-up operation of the FAS.

DK 7320.811

1

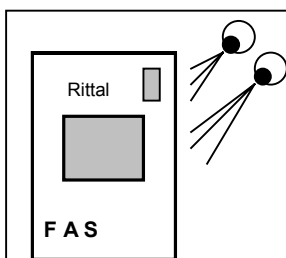

Attention: Prior to installation and commencing operation the installation and operating instructions, including the safety advice, (see 1. **Safety advice**) must be read and observed.

The operating instructions are included as a two-language version (German/ English)

2



Installation: Prior to installation the installing technician must ensure himself of completeness of the scope of supply (see Appendix **A Scope of supply/ Accessories**) including the required accessories. In addition, the technician has to make sure that the allowed operating conditions, in particular regarding the allowed ambient temperature range and the required IP Protection category are maintained, see information Appendix **B Technical data**. See Appendix **D Installation instructions**.

3



Electrical connection:

Attention: It is indispensable to observe the information given in 3.2 Electrical Components and in **Appendix E 1 Electrical connection: Fan Alarm System**.

1. Connect the Fan 7320.812, max 6 and take care of the power supply.
2. Connect the Temperature sensor 7320.500.
3. Optional: Connecting the alarm relays.
4. Optional: Connect the FAS with CMC TC (RJ12 to I/O Unit)
5. Connect the FAS to the power supply.

4

Configuration of the FAS in first-starting:

1. The initialization of the system is signaled after the operation power is supplied through the blinking alarm-LED.
2. Acknowledgement of the connected fan through pressing of the C-key (min. 3 seconds.)

5



Optional – inclusion of the FAS in CMC-TC System:

1. Call browser as normal
2. Enter at http prompt the IP address entered in point 4 of the RITTAL CMC-TC PU :
http://xxx.xxx.xxx.xxx e.g.: <http://130.0.2.242>
The browser window of the PU, shown on left, opens.
3. Status check and settings are made through Status or Setup
4. Alterations are accepted after query for username and password. Works' setting: **cmc** and **cmc**
- 5.



Switch to perfection **RITTAL**

G 1 Display and operating elements at enclosure

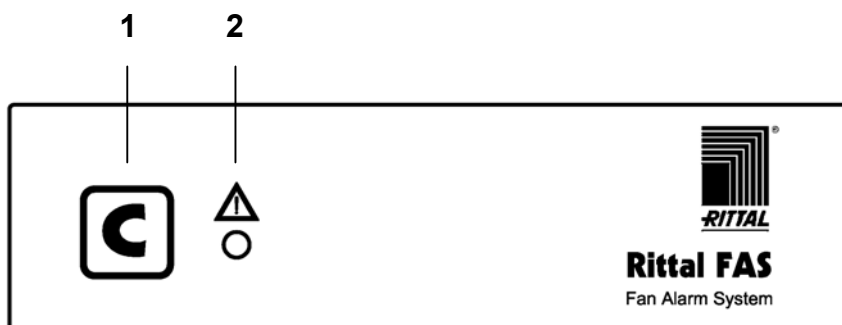

Pos.	Designation	Function	Description
1	Acknowledgement key C	Key	Acknowledgement Key (Quit)
2	LED Status/Alarm	Display	<p>When the LED Fan Alarm System is ...</p> <p>green: in operation, no disturbances</p> <p>red : There exists a defect in the fan.</p> <p>Red/orange/green blinking: Fan connected and/or disconnected (configuration changed).</p>