

Rittal TBU –
Total Benefit of Usership

A large graphic featuring a globe on the left side, partially obscured by the text. The background is a deep blue with several curved, glowing lines in shades of pink, purple, and green that sweep across the right side of the frame.

**Global =
faster
better
more efficient**

More benefits
for your application

25 % faster

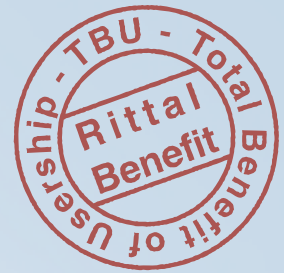

One TBU example of up to "25% faster":

RiCAD 3D

The system that gets straight to the point.

Rittal data compatible with your system

Irrespective of which CAD system you use, RiCAD 3D effectively supports the efficiency and productivity of your plant design.

The delivery includes 2D and 3D drawings of the main Rittal product lines. The database is continuously updated.

You can request drawings free of charge using the configurator or via the online fast selection, and have them sent to you via e-mail. Alternatively, you can also order the CD-ROM and avoid having to use the Internet.

RiCAD 3D CD-ROM with CAD data for:

- AUTOCAD DWG (>R12)
 - ProE 2001
 - ProE Wildfire
 - SolidWorks 3D (= 2003)
 - SolidWorks 3D (≥ 2004)
 - eCabinet by Eplan
 - Neutral Step format
- Further formats available online.

Features

- Considerable reduction of engineering and design work
- Error-free detailed Rittal data
- Generic original data for all CAD systems
- No conversion of neutral formats

www.rittal.com

- User-friendly product configurators

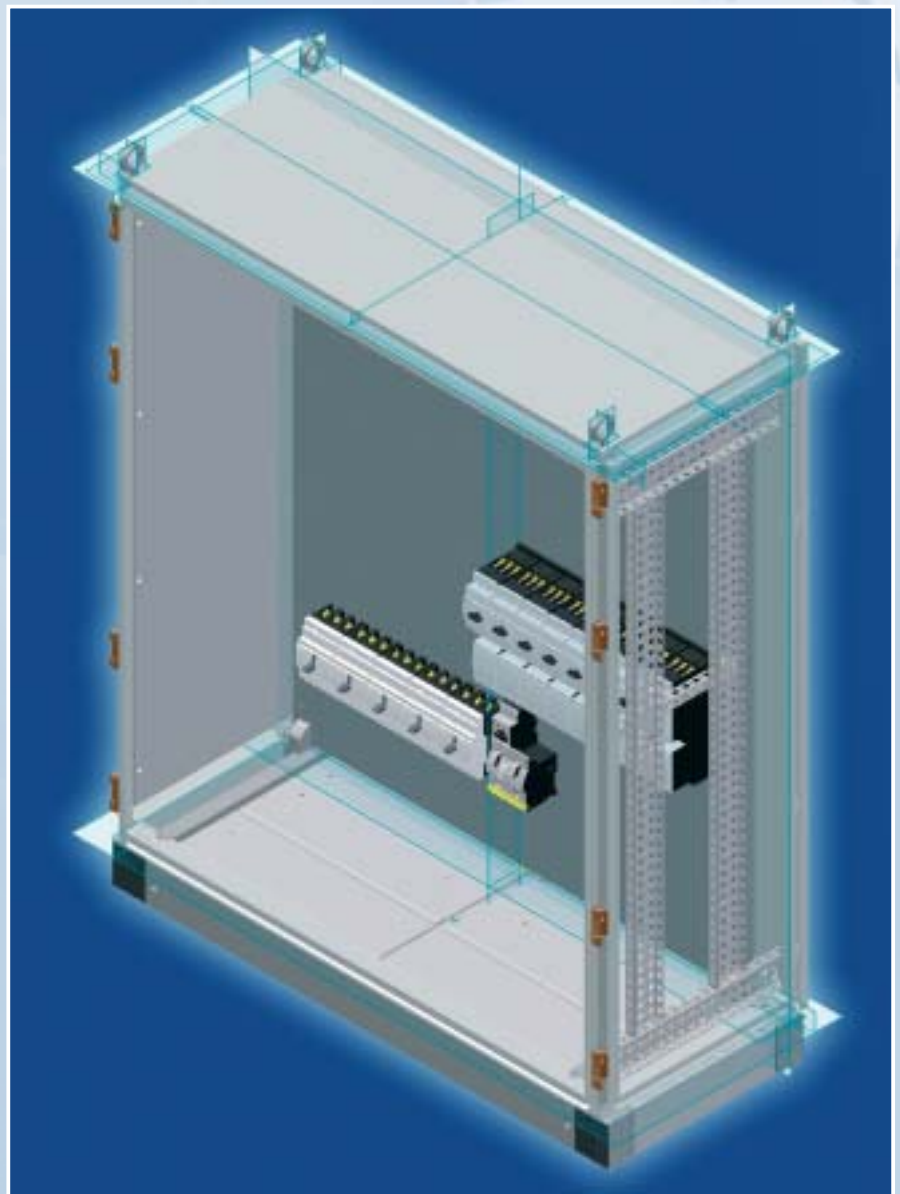
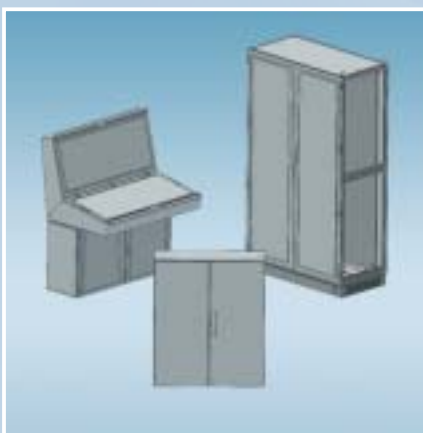

33% better

One TBU example of up to “33% better”:

In the handling and stocking of system accessories

for CM compact system enclosures, TS 8 bayed enclosure system, TS 8 IT network and server racks, outdoor enclosures, TopConsole systems and industrial workstations

We know the widely differing requirement profiles of our customers only too well. The comprehensive “modular” system accessories are geared perfectly to these requirements. The motto is to achieve “as much as necessary with as little as possible” – with practically an endless range of solutions.

The key here is the TS 8 enclosure and IT rack system platform with identical accessories for CM compact system enclosures, TopConsole systems and industrial workstations.

Just assume you employ the use of Rittal CM, TS 8 and the new Rittal TopConsole.

For stocking system accessories, you can equip three different products with a single Rittal accessory, e.g. base/plinth. You can thus compensate fluctuations in demand for accessories for the 3 enclosure applications. Instead of 3 accessory components – 1 per enclosure application – you need no more than 2 of a universally adaptable accessory component.

In this case you reduce your stocks by 33%. Apart from that, you simplify handling during installation when, as in the example, you only need to use one base/plinth.

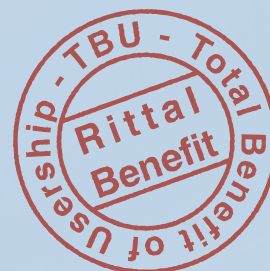

What's so special?

Rittal system accessories – the modular “building kit” for infinite possibilities

Simply better thanks to:

- Lower stocks
- Simpler, quicker installation
- No time-consuming manual processing
- Flexible add-ons and modernisation
- High proven quality of all components
- Rapid worldwide availability

www.rittal.com

- Configurators for TS 8 and CM



30% more efficient

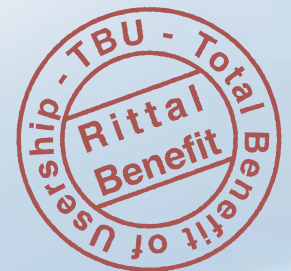

One TBU example of "30% more efficient": Rittal TopTherm Plus cooling unit with RiNano

Savings in energy and maintenance costs through the use of 1500 W Rittal cooling unit applied with RiNano coating in comparison to a unit without RiNano which will become significantly more soiled during the course of operation:

	Energy	Maintenance	Total
Savings per unit			
in 1 year	185 EUR	113 EUR	298 EUR
in 5 years	925 EUR	565 EUR	1,490 EUR
Savings with 20 units			
in 1 year	3,700 EUR	2,260 EUR	5,960 EUR
in 5 years	18,500 EUR	11,300 EUR	29,800 EUR

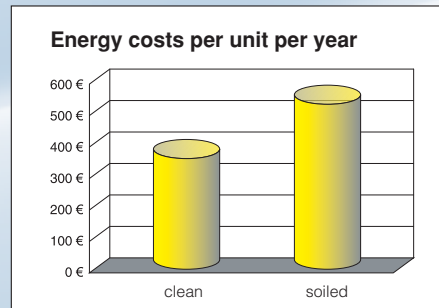

Up to 30% savings in energy. With RiNano coating, the cooling units stay cleaner.

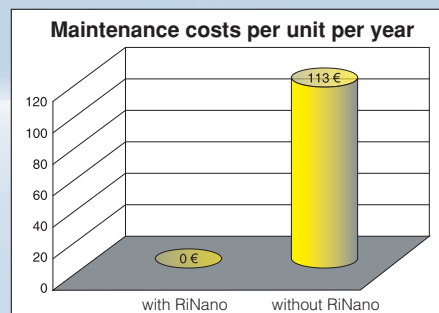

What's so special?

RiNano coating as standard:

- No adhering dirt
- Constantly high efficiency
- Maintenance is reduced or can be completely eliminated
- Energy savings

Condensation evaporation as standard:

- Greater reliability
- No maintenance work for condensate tanks

Test of Rittal TopTherm cooling units with RiNano (as standard!) at Schunk

Despite the graphite dust contamination in the air (machine in the area of the exhaust fume scrubber), the cooling unit is in a maintenance-free condition after 14 months of operation.

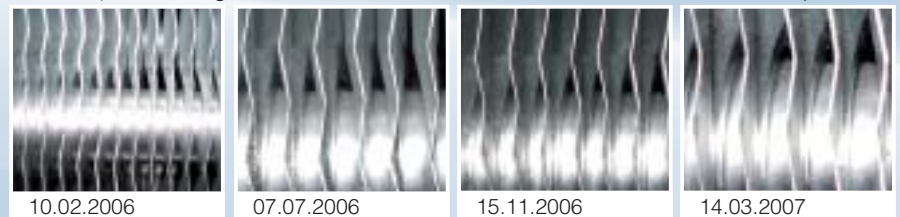

Note

Simpler planning: **Rittal Therm**, the calculation programme for climate control of enclosures.



Rittal TBU = 20%

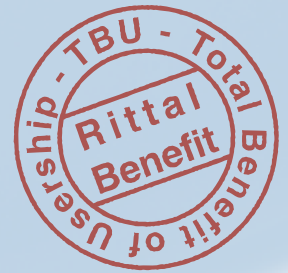

Outstanding – the wide range of benefits of the world's only "system module" for technology packaging. You too can profit from Rittal concepts that are tailored exactly to your requirements.

Our goal: 20% more benefits

The benefits offered through our products and services form the basis for your purchase decision. We can prove convincingly on the following pages that with just three examples we are **25% faster**, **33% better**, **30% more efficient**. With the high benefits that Rittal system solutions offer, you have significant cost advantages over the entire product service life!

Our **TBU consultants** optimise your technology packaging and the associated processes together with you. The calculated personal TBU factor proves in black and white, compared with earlier solutions, that you will achieve significantly more benefits.



What's so special?

Outstanding products, comprehensive service and global presence – the best preconditions for unrivalled benefits for the customer.

- Simplified planning
- Reduced stocks
- Faster installation
- Higher energy efficiency
- Less maintenance

The result?

Convincing, measurable advantages for the user, expressed by the Rittal TBU motto – Total Benefit of Usership



99% global

Where you and your customers are, is where we are, too:

Availability, consultancy, service –
of the same high standard worldwide

Rittal Global Service – faster, better, more efficient



- Five global service stations in the economic hotspots around the world
- 19 Rittal production locations in 11 countries
- Over 60 Rittal subsidiaries with service stations and
- more than 250 qualified partners and Rittal's own technicians – worldwide!

**If you were here,
we certainly would be, too.**



02/08 · E981

Rittal GmbH & Co. KG · Postfach 1662 · D-35726 Herborn
Telephone: +49(0)2772 505-0 · Telefax: +49(0)2772 505-2319 · eMail: info@rittal.de · www.rittal.com



Switch to perfection

RITTAL