



Rittal – Global IT News 2007



Efficient, reliable, flexible

NEW SOLUTIONS TO IMPROVE YOUR IT PERFORMANCE

Progress is a dynamic process. To remain perfect, things need to evolve. There is no perfection without optimisation. Rittal repeatedly sets new standards when it comes to improving your IT performance. The philosophy is clear: Optimum solutions are not considered relevant unless their development incorporates the technical requirements of the future. Thinking ahead, rather than playing catch-up, is the best way of helping customers to move forward. With this in mind, Rittal offers permanent progress to optimise your IT performance at every stage. Innovative solutions provide the foundation in every area. Comprehensive monitoring and top-of-the-range security are essentials. Rittal offers smart packaging, UPS, open distribution frames, FlatBox, wireless sensor technology and video monitoring for the future – scalable and modular.



CONTENTS

Networking, server racks	from page 4
Power	from page 13
Cooling	page 16
Security, monitoring	from page 17
Accessories	from page 29

Rack technology for universal applications

Based on the successful enclosure system TS 8, Rittal rack technology provides the basis for your optimum IT infrastructure.

The **482.6 mm (19") racks** with their fully vented and divided front doors are sure to impress, with their best utilisation of space.

Innovative extensions to the successful **PSM** (Power System Module) **busbar system** in single- and three-phase variants with 32 A phase current and output monitoring.



**Flexibility and compatibility:
Open for your requirements**

The capacity of an IT system cannot only be measured in kilograms. Openness is the prerequisite for future-proofing.

The **Rittal TE 7000 open** offers an infinitely adjustable 482.6 mm (19") distance between levels, free airflow, and a high load-bearing capacity. Another innovative concept from Rittal is the **FlatBox** – a truly ingenious idea. The FlatBox combines low shipping costs with toolless, fast one-man assembly.

Other innovations from Rittal include modular and scalable 1-phase **UPS systems** (Power Modular Concept) for outputs up to 12 kVA N+1 redundant.

Wireless security

Look – no wires! Security made by Rittal means wireless monitoring of your data centre and building management systems.

The Rittal **wireless sensor system** eliminates the need for cabling. The ultra-compact **rack extinguisher system** only requires 1 U of installation space in the rack, and is available with or without an extinguisher tank.

Networking

Network enclosures, based on Rittal TE 7000, metric attachment levels

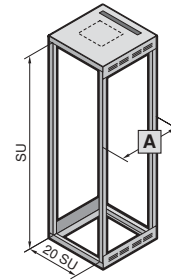
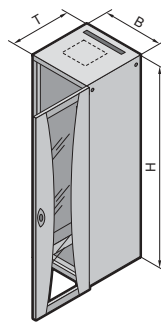

Benefits:

- Configured to order
- No frame structure, maximum cable routing
- Load capacity up to 400 kg

Material:

Sheet steel

Surface finish:

Nanoceramic coating, electrophoretic dipcoat-priming, powder-coating in RAL 7035.

Supply includes:

Self-supporting metric frame structure, glazed door at the front, two-point locking rod, recessed handle and security lock 3524 E, sheet steel door at the rear,

two-point locking rod, recessed handle and security lock 3524 E, plug-in side panels with security lock 3524 E, base frame with maximum cut-out (for optional population with module plates), roof plate for cable entry with concealed cut-out for fan, spacers for raising the cover plate, levelling feet.

Detailed drawing, available on the Internet.

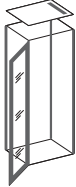
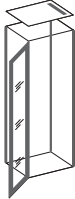
		
SU	76	82
Width (B) mm²	600	600
Height (H) mm²	2000	2200
Depth (T) mm²	600	600
Metric distance between levels as delivered A	495	495
Model No. TE	7000.508¹⁾	7000.568¹⁾
Model No. TE as bayed enclosure without side panels, including baying kit	7000.504¹⁾	7000.564¹⁾

¹⁾ Delivery times on request. ²⁾ All sizes given are nominal dimensions. For absolute dimensions, please refer to the detailed drawing on the Internet.

A 495 mm – This is the distance between the two metric levels for all enclosure formats in their delivered state. Complies with TS 8 nominal depth 400 mm, inner level. The distance between levels is freely selectable via the slot fastening.

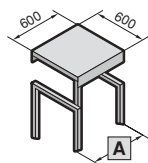

Size systems

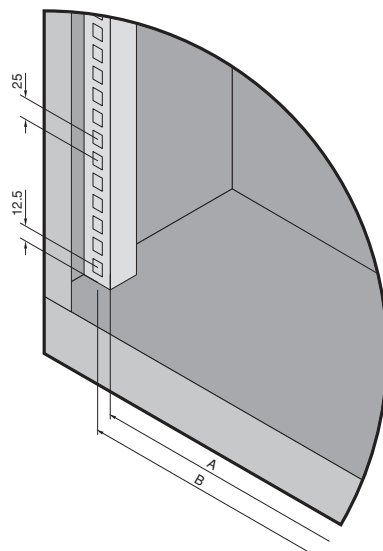

Explanation of the mounting dimensions Interior installation

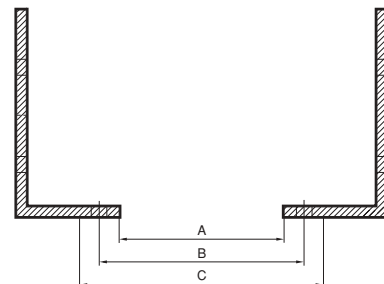

Installation width	A mm	B mm	C mm
20 SU	500	515	535

A = Clearance width
B = Mounting dimension
C = External dimension of slide-in equipment or front panel

Network enclosures, based on Rittal TS 8, pre-configured

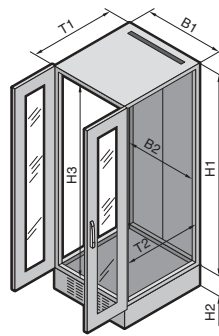

V7

Glazed front door, vertically divided, 180°, sheet steel rear door, vertically divided, 180°. 482.6 mm (19") mounting angles at the front and rear, distance between levels pre-configured at 498 mm.

Cranked mounting angles screw-fastened to installation brackets approx. 150 mm behind the frame front edge.

Gland plate at the front, fitted as an infill panel.

Material:
Sheet steel

Surface finish:
Enclosure frame:
Dipcoat-primed
Doors, roof and base/plinth:
Dipcoat-primed,
powder-coated in RAL 7035

Gland plates, punched sections with mounting flanges and mounting angles:
Zinc-plated, passivated

Supply includes:
Enclosure frame with doors or rear panel, roof plate, vented base/plinth 100 mm, earthing of all enclosure panels

Supplied loose:
Levelling feet incl. base/plinth adaptor,
4 spacers, for raising the roof,
4 cable clamp rails for the inner frame level,
10 cable shunting rings (105 x 70 mm, plastic),
50 captive nuts, M6, conductive,
50 multi-tooth screws M6.

Detailed drawing,
available on the Internet.

U		42
Width (B1) mm		800
Height (H1 + H2) mm		2000 + 100
Depth (T1) mm		800
Clearance width (B2) mm		712
Clearance height (H3) mm		1812
Clearance depth (T2) in mm		712
Model No. DK as bayed enclosure without side panels, including baying kit TS 8800.500	V7	7830.260
Accessories		Cat. 31, page
Two plug-in side panels, with security lock 3524 E		7824.208 855



Wall-mounted enclosure, based on Rittal EL, 3-part, pre-configured, depth 673

Material:
Wall and hinged part:
Sheet steel, 1.5 mm
Viewing window:
3 mm safety glass.

Colour:
Wall and hinged part: Spray-finished in RAL 7035
Glazed door: RAL 7035/7015 (slate grey).

Protection category:
Max. IP 43 to EN 60 529/10.91
when using solid gland plates

Detailed drawing,
available on the Internet.

Supply includes:

Wall section:
With vertical punched rails and C rail mounted horizontally for cable clamping, top cable gland plate solid, bottom cable gland plate with brush strips, earthing rail with star earthing, wall mounting bracket 10 mm.

Hinged part:
With 25 mm pitch pattern of holes in the front and rear frame, two 482.6 mm (19") mounting angles mounted on C rails, infinitely depth-variable, one outlet filter each on the left and right side.

Designer glazed door:
With 3 mm single-pane safety glass window, 9 + 15 U with mini comfort handle for lock inserts, 21 U with comfort handle and 2-point locking, including lock 3524 E.

U	Packs of	9	15	21
Width (B1) mm		600	600	600
Height (H1) mm		478	746	1012
Depth (T1) mm		673	673	673
Clearance width (B2) mm		502	502	502
Clearance height (H2) in mm		417	684	951
Depth of wall section (T2) mm		135	135	135
Depth of hinged part (T3) mm		516	516	516
Maximum installation depth (T4) mm		620	620	620
Model No. DK	1	7709.535	7715.535	7721.535
Load capacity, hinged part (kg)		45	75	75

Networking

TE 7000 open

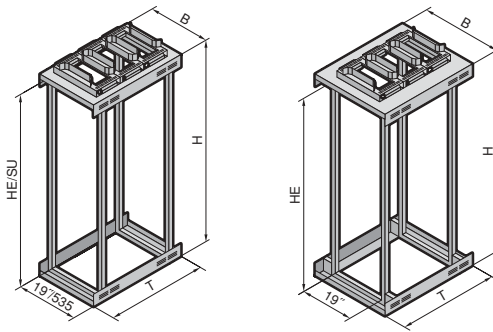

HE = U

Benefits:

Unlimited applications covering all tasks in the IT sector. Both as a network distribution frame with maximum accessibility from all sides for assembly and installation, and as a server rack with a high load capacity of up to 700 kg. Unrestricted airflow, thanks to the open design. The standard cable trays in the roof area mean that even large quantities of cables are easily routed to the various levels without kinks.

In a bayed configuration, the 800 mm width in particular offers plenty of space for cable routing between units. There is an extensive range of accessories available for individual cable management solutions. The distance between attachment levels is infinitely variable.

Material:

Sheet steel

Surface finish:

Powder-coated, RAL 7035





Load capacity:

700 kg

Supply includes:

Self-supporting frame structure, with a 482.6 mm (19") or metric attachment level front and rear depending on the design. Open roof frame for cable entry, 3 cable routing trays. Open base frame with 2 punched sections with mounting flanges for individual configuration in the width, levelling feet.

Detailed drawing, available on the Internet.

				
U/SU	42/76	47/82	42/-	47/-
Width (B) mm	600	600	800	800
Height³⁾ (H) mm	2000	2200	2000	2200
Depth (T) mm	1000	1000	1000	1000
Distance between levels (mm) as delivered	745	745	745	745
Model No. TE with 482.6 mm (19") attachment level	7000.940	7000.942	7000.944	7000.946
Model No. TE with metric (535 mm) attachment level	7000.960¹⁾	7000.962¹⁾	-	-
482.6 mm (19") accessories	Packs of			
Cable management panel 482.6 mm (19"), 1 U for horizontal cable routing, with 5 steel rings, zinc-plated, passivated, size 100 x 37 mm	1	7257.035	7257.035	7257.035
Cable management panel 482.6 mm (19"), 2 U for horizontal cable routing, with 5 steel rings, zinc-plated, passivated, size 120 x 80 mm	1	7257.100	7257.100	7257.100
Shunting rings to accommodate large quantities of cables, for mounting on the side of the mounting frame, dimension 300 x 90 mm	2	7220.600	7220.600	7220.600
Cable management panel 482.6 mm (19"), 2 U for horizontal cable routing, with removable front panel	1	7158.100	7158.100	7158.100
Component shelf 482.6 mm (19"), 1/2 U static installation, depth-variable in the range from 600 – 900 mm	1	7063.720	7063.720 ²⁾	7063.720
Slide rail 482.6 mm (19"), load capacity 100 kg, for 482.6 mm (19") distance between levels (internal) 740 mm	2	7063.740	7063.740 ²⁾	7063.740
Slide rail 482.6 mm (19"), depth-variable in the range from 390 – 600 mm, load capacity 80 kg	2	7063.882	7063.882 ²⁾	7063.882
Slide rail 482.6 mm (19"), depth-variable in the range from 590 – 930 mm, load capacity 80 kg	2	7063.883	7063.883 ²⁾	7063.883
C rail, variable within the range 450 – 850 mm	1	7016.140	7016.140	7016.140
T-head rail, variable within the range 450 – 850 mm	1	7016.150	7016.150	7016.150
Cable route for vertical cable management, for mounting at the side rear of the 482.6 mm (19") mounting frame, W = 100 mm, H = 1700 mm	1 set	7000.685	7000.685	7000.685

¹⁾ Delivery times available on request.

²⁾ Not suitable for use with a metric attachment level.

³⁾ Plus 100 mm roof-mounting/cable-routing trays.

FlatBox features



The innovative concept behind the FlatBox unites **optimised storage and shipping costs** with cleverly designed, tool-less, **fast one-person assembly**. As you would expect, Rittal prides itself on details. Compatible with the extensive range of existing system accessories, and can be used as a **wall-mounted or floor-standing enclosure**. Unrestricted accessibility during installation of the network components. The width and depth dimension of 700 mm provides plenty of space for use as a patch distributor, and small networks with active technology are also ideal for climate control via the fan panels (maximum of 8).



Pre-assemble the base frame, locate into the attachment points on the wall, and secure.



Configuration of the open enclosure is now possible. Slide the roof and gland plates into position,



insert the side panels, locate and lock the door, and it's done! If the FlatBox is used as a floor-standing enclosure, levelling feet are fastened to the gland plate.



The **levelling feet** allow the FlatBox to be used as a desktop enclosure, e.g. in measurement and control technology, or as an underdesk enclosure in the form of a small network node.



Optimum cable entry via brush strips top and bottom, plus plenty of space for cable distribution in the enclosure depth. Even active components with pre-assembled connectors may be routed.



The snap connection system facilitates **toolless enclosure assembly**. Once clipped into place, a very stable enclosure is created with a high static load capacity of 5 kg/U or a maximum of 75 kg.

Networking

FlatBox

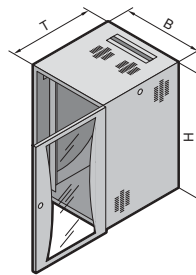

Material:
Sheet steel

Surface finish:
Powder-coated in RAL 7035

Supply includes:
Flat-packed enclosure,
1 wall section, 2 basic supports,
2 roof/gland plates, with cut-outs
for cable entry, with brush strips,
2 482.6 mm (19") mounting
angles (for 6 U and 9 U),

1 482.6 mm (19") mounting
frame (from 12 U),
4 levelling feet (from 12 U),
2 side panels, lockable,
1 glazed door, lockable, door
hinge point selectable.

Earth straps for earthing of
panels.
Components for toolless,
fast assembly.

With 482.6 mm (19") mounting angles at the front and glazed door	Packs of					Page
U		6	9	6	9	
Width (B) mm		600	600	600	600	
Height (H) mm		358	492	358	492	
Depth (T) mm		400	400	600	600	
Model No. DK	1	7507.000	7507.010	7507.100	7507.110	
Accessories						
19" mounting angles as 2nd attachment level, 6 U	2	7507.706	–	7507.706	–	9
19" mounting angles as 2nd attachment level, 9 U	2	–	7507.709	–	7507.709	9
Levelling feet	4	7507.740	7507.740	7507.740	7507.740	9
Cover plates for fan panels	6	7507.760	7507.760	7507.760	7507.760	9
Earth rail	1	7113.000	7113.000	7113.000	7113.000	Cat. 31/962
C rail for cable clamping	1	7016.140	7016.140	7016.140	7016.140	37
T-head rail for cable clamping	1	7016.150	7016.150	7016.150	7016.150	37
Fan, 230 V AC, 50/60 Hz, 117/135 m³/h, air throughput, unimpeded airflow	1	7980.100	7980.100	7980.100	7980.100	Cat. 31/649
Fan, 48 V DC, 184 m³/h, air throughput, unimpeded airflow	1	7980.148	7980.148	7980.148	7980.148	Cat. 31/649
Thermostat	1	3110.000	3110.000	3110.000	3110.000	Cat. 31/661

With 482.6 mm (19") mounting frame at the front and glazed door	Packs of							Page
U		12	15	12	15	18	21	
Width (B) mm		600	600	600	700	700	700	
Height (H) mm		625	758	625	758	892	1025	
Depth (T) mm		400	400	600	700	700	700	
Model No. DK	1	7507.020	7507.030	7507.120	7507.200¹⁾	7507.210¹⁾	7507.220¹⁾	
Accessories								
19" mounting angles as 2nd attachment level, 12 U	2	7507.712	–	7507.712	–	–	–	9
19" mounting angles as 2nd attachment level, 15 U	2	–	7507.715	–	7507.715	–	–	9
19" mounting angles as 2nd attachment level, 18 U	2	–	–	–	–	7507.718	–	9
19" mounting angles as 2nd attachment level, 21 U	2	–	–	–	–	–	7507.721	9
Cover plates for fan panels	6	7507.760	7507.760	7507.760	7507.760	7507.760	7507.760	9
Earth rail	1	7113.000	7113.000	7113.000	7113.000	7113.000	7113.000	Cat. 31/962
C rail for cable clamping	1	7016.140	7016.140	7016.140	7016.140	7016.140	7016.140	37
T-head rail for cable clamping	1	7016.150	7016.150	7016.150	7016.150	7016.150	7016.150	37
Fan, 230 V AC, 50/60 Hz, 117/135 m³/h, air throughput, unimpeded airflow	1	7980.100	7980.100	7980.100	7980.100	7980.100	7980.100	Cat. 31/649
Fan, 48 V DC, 184 m³/h, air throughput, unimpeded airflow	1	7980.148	7980.148	7980.148	7980.148	7980.148	7980.148	Cat. 31/649
Thermostat	1	3110.000	3110.000	3110.000	3110.000	3110.000	3110.000	Cat. 31/661

¹⁾ Pre-configured variant available on request.



Mounting angles

L-shaped bracket as 2nd attachment level.

Material:
Sheet steel

Supply includes:
Assembly parts for fast, toolless assembly.

U	Packs of	Model No. DK
6	2	7507.706
9	2	7507.709
12	2	7507.712
15	2	7507.715
18	2	7507.718
21	2	7507.721

Note:

The 2nd attachment level should always be ordered in the same height as the basic enclosure. Partial configuration is not possible.



Levelling feet

M10 x 20 mm

For fastening onto the enclosure base when used as a floor-standing or desktop enclosure.
Width across flats 17, mounting thread multi-tooth 30.

Packs of	Model No. DK
4	7507.740



Cover plates for fan panels

To cover unused fan panels when using fans in the FlatBox.

Material:
Sheet steel

Surface finish:
Powder-coated in RAL 7035

Supply includes:
Assembly parts.

Packs of	Model No. DK
6	7507.760

Server racks

Based on Rittal TS 8, pre-configured

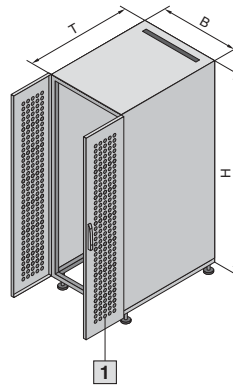

Design features:

- Robust frame structure
- Front and rear door fully vented; free vented surface area 78 % perforated
- 4-point locking
- Door hinge may be swapped to opposite side without any machining
- Cable entry via the roof and base
- Bayable at all levels
- Load capacity up to 1000 kg.

Material:
Sheet steel

Surface finish:
Enclosure frame:
Dipcoat-primed
Enclosure panels:
Dipcoat-primed,
powder-coated in RAL 7035 or
RAL 9005
Mounting frame:
Zinc-plated, passivated

Supply includes:
Enclosure frame TS 8 with sheet steel doors, vertically divided, vented front and rear, depth-variable 482.6 mm (19") mounting frame front and rear, levelling feet, comfort handle with security lock and 4-point lock.

Fitted with standard lock 3524 E. Enclosure panel earthing already pre-fitted. Two-piece roof plate, with sliding plate and rubber cable clamp strip for cable entry. Without or with side panels in colours RAL 7035 and RAL 9005.

Detailed drawing, available on the Internet.

- 1** Optimised air flow. Open surface area 78 % perforated.

Number of front and rear doors	2 (vertically divided)	2 (vertically divided)	2 (vertically divided)	2 (vertically divided)
U	42	42	42	42
Width (B) mm	800	800	800	800
Height (H) mm	2000	2000	2000	2000
Depth (T) mm	1200	1200	1200	1200
Model No. DK	7831.489	7831.499	7831.580	7831.590
RAL colour	7035	7035	9005	9005
Doors				
Sheet steel doors, vented, front and rear ¹⁾	■	■	■	■
Plug-in side panels with T lock	-	■	-	■
Roof				
Roof plate, two-piece with rubber cable clamp strip for cable entry	■	■	■	■
Base				
Open base frame	■	■	■	■
Levelling feet	■	■	■	■
Interior installation				
482.6 mm (19") level, front and rear	■	■	■	■
482.6 mm (19") mounting frames, front and rear	■	■	■	■
Load capacity 1000 kg	■	■	■	■
Panel earthing, fitted	■	■	■	■
Accessories				
Security lock for side panels	7824.500	7824.500	8601.802	7824.500
Base/plinth components, front and rear, solid	8601.805	8601.805	8601.802	8601.802
Base/plinth trims	8601.025	8601.025	8601.026	8601.026
Base mounting bracket	8800.210	8800.210	8800.210	8800.210
Stabiliser, pull-out	7825.260	7825.260	7825.260	7825.260

■ Included with the supply. ¹⁾ Open surface area in perforated plate part 78 %.

Smart Package, pre-configured



The Smart Package racks based on the successful TS 8 enclosure system provide the ideal basis for your IT infrastructure.

These server racks are equipped with the power distribution concept PSM (Power System Module).

Additional accessories for assembly and cable routing are supplied loose.



482.6 mm (19") mounting frames

Thanks to the two 482.6 mm (19") mounting frames, the rack has a high load capacity of 1000 kg in the 482.6 mm (19") level. The distance between levels of the two 482.6 mm (19") frames are adjustable to the required dimensions of the installation kits supplied by the server manufacturers, enabling the installation of virtually any type of server.

Doors/walls

The fully vented front and rear doors with an open surface area of 78 % in the perforated plate part ensure that the air path of the servers is not restricted. Hot air is able to escape easily at the rear. Thanks to the 4-point locking of the doors (door hinge may be swapped for 130° hinges) and the screw-fastened side panels, the installed equipment is protected from unauthorised access.

With the TS comfort handle system for semi-cylinders, the lock supplied may be exchanged at any time for a customer-specific model.

Plug and play power distribution

The plug & play power distribution concept PSM (Power System Module) is pre-integrated and fitted with selected modules in the factory. It may be extended at any time with up to 4 modules with various connector configurations. The required connection cables to supply the busbar with power are also included with the supply.

Cable management

Cable entry is via the base/plinth or the divided roof plate. In order to be able to begin server integration immediately, additional accessories for assembly, cable routing and attachment are supplied loose.

Material:
Sheet steel

Colour:
RAL 7035

Surface finish:
Enclosure frame: Dipcoat-primed, enclosure panels dipcoat-primed and powder-coated in RAL 7035 (light grey)
482.6 mm (19") mounting frame: Zinc-plated, passivated

Design features:

- Robust frame structure
- Front and rear door fully vented; open surface area 78 % in the perforated plate part
- 4-point locking of the doors
- Door hinge may be swapped to opposite side
- Side panels screw-fastened from the inside
- Cable routing via the roof and base
- Bayable at all levels
- Load capacity up to 1000 kg
- PSM busbar 2 m, for up to 7 PSM modules.

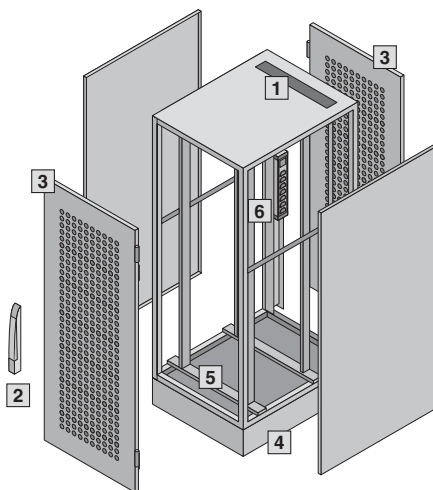

- 1 Roof plate for cable entry, two-piece
- 2 Comfort handle
- 3 Sheet steel door, vented
- 4 Base/plinth with levelling feet
- 5 482.6 mm (19") mounting frame
- 6 PSM busbar with plug-in modules

Server racks

Smart Package, pre-configured

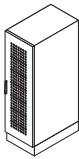
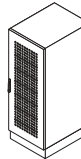
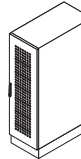
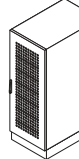
				
Smart Package – pre-configured server racks with power distribution concept PSM (Power System Module)	A4	A5	A6	A7
U	42	42	42	42
Width mm	600	800	600	800
Height mm	2000 + 100	2000 + 100	2000 + 100	2000 + 100
Depth mm	1000	1000	1200	1200
Model No. DK (German version, with earthing-pin plug-in module)	7337.440	7337.450	7337.460	7337.470
Model No. DK (international version, without earthing-pin plug-in module)	7337.445	7337.455	7337.465	7337.475
Supply includes				
Doors				
Sheet steel doors, vented, front and rear ¹⁾	■	■	■	■
Comfort handle for semi-cylinder front and rear, including security lock 3524 E	■	■	■	■
Side panel				
Side panels, screw-fastened	■	■	■	■
Roof				
Roof plate with rubber cable clamp strip for cable entry, two-piece	■	■	■	■
Base				
Base/plinth, solid, with levelling feet	■	■	■	■
Base frame to accommodate optional gland plates	■	■	■	■
Interior installation Model No. DK				
482.6 mm (19") mounting frames front and rear	■	■	■	■
Central earthing connection point	7829.200	■	■	■
Earthing of all enclosure panels	7529.150	■	■	■
PSM busbar (Power System Module)	7856.020	■	■	■
Mounting kit for PSM busbar	7856.011	■	■	■
2 x plug-in modules EN 60 320 C13 (IEC 320 connector)	7856.080	■	■	■
1 x plug-in module, earthing-pin type (German version only)	7856.100	■	■	■
Supplied loose				
PSM connection cable, 3-phase	7856.025	7856.025	7856.025	7856.025
PSM connection cable, 1-phase	7856.026	7856.026	7856.026	7856.026
10 x cable shunting rings 125 x 65 mm/nylon loops 200 mm	7072.230	7111.000	7072.230	7111.000
10 x 1 U blanking panel, toolless fixing	7151.110	7151.110	7151.110	7151.110
2 x 1 U cable management panel	7257.035	7257.035	7257.035	7257.035
20 x cable lock for EN 60 320 C13/C14 connectors	7856.013	7856.013	7856.013	7856.013
50 x 482.6 mm (19") slot-in cable gland	2094.400	2094.400	2094.400	2094.400
Accessories (available to order separately)				
Monitor/keyboard unit, 1 U with 15" TFT display, touchpad (German)	9055.100	9055.100	9055.100	9055.100
Monitor/keyboard unit, 1 U with 15" TFT display, touchpad (English)	9055.102	9055.102	9055.102	9055.102
SSC compact, Economy 8-port KVM switch	7552.010	7552.010	7552.010	7552.010
Supply connection cable for SSC compact	7200.210	7200.210	7200.210	7200.210
CPU cable 2 m (with interlocking PS/2 connectors) for SSC compact	7552.120	7552.120	7552.120	7552.120
CPU cable 4 m for SSC compact	7552.140	7552.140	7552.140	7552.140
Component shelf 700 mm, 482.6 mm (19") population, heavy duty, 100 kg	7063.897	7063.897	7063.897	7063.897
Installation kit, depth-variable, for component shelf, 100 kg	7063.890	7063.890	7063.890	7063.890
Telescopic slide, 100 kg	7066.700	7066.700	7066.700	7066.700
Slide rail, depth-variable, 590 – 930 mm, 50 kg	7063.883	7063.883	7063.883	7063.883
1/2 U component shelf, pull-out, 600 – 900 mm, static installation	7063.720	7063.720	7063.720	7063.720
PSM plug-in module, 6 x EN 60 320 C13 IEC 320 equipment	7856.080	7856.080	7856.080	7856.080
PSM plug-in module, EN 60 320 C19 x 4	7856.230	7856.230	7856.230	7856.230
PSM plug-in module, 4 x earthing-pin	7856.100	7856.100	7856.100	7856.100
PSM light module (portable light)	7856.210	7856.210	7856.210	7856.210

■ Pre-configured. ¹⁾ Open space in the perforated plate part 78 %.

Power System Module PSM/Power Distribution Module PDM

**PSM busbar**

Single- and three-phase design with 32 A phase current.

Technical specifications:

- Single- and three-phase design with a max. current of 32 A per phase, 1 x 32 A or 3 x 32 A, 400/230 V, 50/60 Hz
- Accommodates up to 6 passive PSM modules
- Integral circuit-breaker 16 A, Class C
- Modules may be retrofitted whilst the system is operational.

Supply includes:

Busbar with CEE-conforming connector, assembly parts, instructions.



Enclosure height mm	Number of modules	Model No. DK	
		single-phase	three-phase
2000	6	7856.321	7856.323

**Also required:**

Mounting kit, see Cat. 31, page 744 and Innovations 2005/2006, page 140.
PSM plug-in module, see Cat. 31, page 745 and Innovations 2005/2006, page 138.

**Accessories:**

PSM cable lock, see Innovations 2005/2006, page 141.

**Active PSM 6-way, individually switchable**

For further details, see Innovations 2005/2006, page 138.

Material:

Aluminium section with plastic cover

Supply includes:

- 1 module (max. 16 A per module),
- 1 bus cable,
- 1 infeed cable 24 V DC.

Design	Model No. DK
2 x C13 and 4 x C19	7856.204
2 x C13 and 4 x earthing-pin	7856.203

**Also required:**

In stand-alone mode without CMC-TC, a separate power pack (100 – 240 V AC/24 V DC) is required (**DK 7201.210**) together with the corresponding connection cables, see Innovations 2005/2006, page 138.

**PDM socket strip**

Socket strip for the direct connection of single-phase equipment to a Power Distribution Module PDM

482.6 mm (19") power distributor with three-phase infeed. The standard plug & play connection cables may be used. Each group of three colour-coded connectors is supplied by one phase.

Benefits:

- Simple connection of single-phase equipment when using PDM
- Compatible with standard plug & play connection cables
- Prepared for the connection of **LCP, CMC-TC, SSC** etc.

Design	Model No. DK
6 x C13/3 x earthing-pin	7857.325

Technical specifications:**Input:**

Mains voltage: 400 V/50 Hz, three-phase
Rated current: 16 A per phase
Connection: X-Com connector

Output:

Mains voltage: 230 V/50 Hz, single-phase
Rated current: 10 A per phase

UPS, single-phase, output range 1 – 12 kVA N+1 redundant



Rittal Power Modular Concept PMC 12

- Double conversion technology VFI-SS 111
- For use as a rack or floor-standing enclosure with 90° rotating LCD display
- 2 U high
- Serial/USB interface and Emergency Power Off (EPO) contact
- Batteries "hot swap" compatible, may be exchanged from the front
- Integral batteries with 1 – 3 kVA
- External batteries with 4.5 kVA and 6 kVA
- Parallel switching 4.5 kVA and 6 kVA UPS up to 12 kVA N+1 redundant
- Optional SNMP card

DK 7857.430, DK 7857.431, DK 7857.432

Supply includes:

Single-phase UPS systems in double-conversion technology (VFI-SS 111) with internal "hot swap" compatible batteries, USB and serial interface.

DK 7857.433, DK 7857.434

Supply includes:

Single-phase UPS systems in double-conversion technology (VFI-SS 111), USB and serial interface.

Available on request:

Replacement battery packs and AS 400 interface adaptor.



Also required:

Country-specific connection cables and slide rails are required to operate the UPS systems.

For DK 7857.433, DK 7857.434

Parallel Hot Swap Chassis (DK 7857.443 or DK 7857.444). External 3 U battery pack (DK 7857.442).

UPS for 482.6 mm (19") racks or as floor-standing enclosures		UPS with integral battery			UPS control unit	
Model No. DK		7857.430	7857.431	7857.432	7857.433	7857.434
Power	VA	1000	2000	3000	4500	6000
	Watts	700	1400	2100	3150	4200
	Max. heat loss (W)	105	210	252	315	420
Input	Rated voltage	230 V (160 – 288 V)				
	Frequency	50/60 Hz ±5 %				
	Power factor	> 0.99 with linear load				
Output	Voltage	230 V ± 1 % (200/208/220/230/240 V adjustable)				
	Frequency, synchronised	± 1 Hz				
	Frequency, asynchronous	±0.1 %	±0.1 %	±0.1 %	±0.2 %	±0.2 %
	Crest factor	3 : 1				
	Non-linear distortion	≤ 7 %	≤ 7 %	≤ 7 %	≤ 6 %	≤ 6 %
	Wave shape	≤ 3%				
	Operating ratio, AC mode	85 %	85 %	88 %	90 %	90 %
	Operating ratio, battery mode	83 %	83 %	85 %	87 %	87 %
Power factor	0.7					
Battery		5 years EUROBAT	5 years EUROBAT	5 years EUROBAT	5 years EUROBAT	5 years EUROBAT
	Autonomy at 100 % load	≥ 7 min	≥ 7 min	≥ 5 min	≥ 12 min	≥ 8 min
Overload	105 %	continuous				
	120 %	30 sec	30 sec	30 sec	160 sec	160 sec
	150 %	10 sec	10 sec	10 sec	160 sec	160 sec
Communication	Interface	1 x USB, 1 x RS232				
	SNMP	Optional SNMP card DK 7857.420				
	Operating systems supported	Windows, Unix, Linux, OS/2, Novell, Apple; RCCMD shutdown licence DK 7857.421				
	Emergency Power Off (EPO)	■				
Mechanics	Width mm	440				
	Height mm	88				
	Depth mm	405	650	650	660	660
	Weight kg	15.7	29.4	29.7	24	24
	Input connection 230 V	10 A C14			10 A C20	Compact connector
Output connection 230 V	6 x 10 A, C13, 2 units switched			4 x 10 A, C13, 2 units switched 1 x 16 A, C19	Compact connector	Compact connector
Operating environment	Humidity	0 – 90 %, non-condensing				
	Noise level	50 db (A)				
	Safety	IEC/EN 62 040-1, EN 60 950-1				
Standards and certifications	Power	IEC/EN 62 040-3				
	EMC	EN 50 091-2/EN 62 040-2 class A, EN 61 000-4-2/-3/-4/-6-8/-11, EN 61 000-3-2/-3				
	Labelling	CE, FCC, cUL				

UPS, single-phase, output range 1 – 12 kVA N+1 redundant

Accessories for Model No. DK	7857.430	7857.431	7857.432	7857.433	7857.434
External bypass ^{1) 5)}	7857.439	7857.440	7857.441	–	–
Battery pack ²⁾	7857.435	7857.436	7857.437	7857.442	7857.442
Parallel Hot Swap Chassis for 2 UPS systems ³⁾	–	–	–	7857.443	7857.443
Parallel Hot Swap Chassis for 3 UPS systems ³⁾	–	–	–	7857.444	7857.444
PDM for PMC 12 ⁴⁾	–	–	–	–	7857.445
SNMP card	7857.420	7857.420	7857.420	7857.420	7857.420
RCCMD shutdown licence	7857.421	7857.421	7857.421	7857.421	7857.421
Connection cable, UPS, single-phase	7856.027	7856.027	–	–	–
Connection cable, UPS, single-phase, C20	–	–	7856.030	–	–
Slide rail, depth-variable	7063.883	7063.883	7063.883	7063.883	7063.883

⁵⁾ Extended delivery times.

Block diagram parallel redundant UPS DK 7857.433/.434

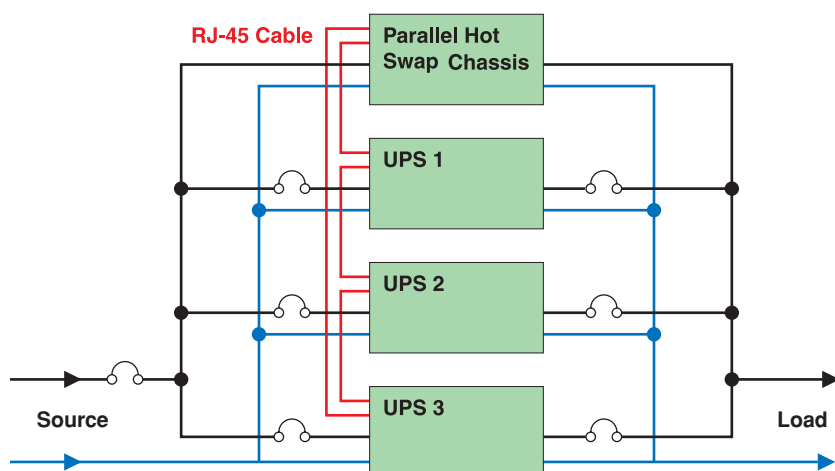

1) External bypass:

The external bypass allows the UPS to be swapped with the system operational.

2) Autonomy (min.) at 100 % load:

UPS type	In supplied state	Battery packs		
		1	2	3
1 kVA	7 min	1:09 h	2:13 h	–
2 kVA	7 min	34 min	1:09 h	–
3 kVA	5 min	30 min	1:02 h	–
4.5 kVA	–	12 min	31 min	54 min
6 kVA	–	8 min	20 min	36 min

3) Parallel Hot Swap Chassis:

The Parallel Hot Swap Chassis for the 4.5 kVA and 6 kVA module allows up to 3 UPS systems to be connected together. This can be used to boost output and to achieve N+1 redundancy. An external bypass is additionally integrated into the Parallel Hot Swap Chassis.

4) PDM for PMC 12:

1-phase power distribution for use with the Parallel Hot Swap Chassis DK 7857.444. The PDM offers the opportunity of connecting two 1-phase 32 A CEE connectors and four EN 60 320 C19 16 A connectors. All outputs have pre-fuses.



Sub-distributor 482.6 mm (19") UPS, modular

The distributor may be fitted directly in the UPS PMC 200 rack. This allows a compact complete system to be realised with a 0.6 m² footprint that contains a rack-mounted modular UPS PMC 200, batteries and distributor.

The sub-distributor is installed in the rear area of the rack where the PSM busbars (installed in the racks) are attached directly using connectors. Twelve three-phase outlets are available on the distributor, meaning that a maximum of twelve racks can be supplied. In addition, 10 A circuit-breakers are integrated for each phase. These components are perfectly tailored to the UPS systems PMC 200 up to 20 kW N+1. The 12-way sub-distributor is designed for use in conjunction with the modular UPS systems PMC 200. The server racks can be attached directly using plug & play technology with connection cables DK 7857.1XX.

Design	Model No. DK
19", 6 U	7857.372

Application area:

UPS systems Rittal Power Modular Concept PMC 200 up to 20 kW N+1, see Innovations 2005/2006, page 142.

Technical specifications:

- 482.6 mm (19"), 6 U
- 12 outlets, 3-phase 400 V/50 Hz with 10 A
- On-load isolator for disconnecting
- Circuit-breaker 10 A per phase

Supply includes:

482.6 mm (19") modules, 6 U, instructions

Note:

Observe the country-specific connection data.



Also required:

Plug & play connection cable to the server racks:

Length	Packs of	Model No. DK
3 m	1	7857.130
5 m	1	7857.150
8 m	1	7857.180
9 m	1	7857.190

Cooling

Roof-mounted cooling unit, useful cooling output 3000 W

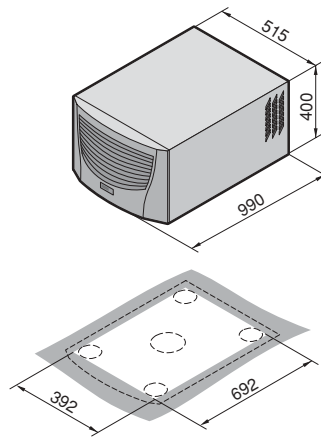

For office applications.

Special internal air routing conveys the cold air directly from the front 482.6 mm (19") level and can then be drawn in directly by the active installed equipment. The cold air temperature-dependent control effectively prevents condensation.

Supply includes:

Nano-coated condenser and integral condensate evaporation. Fully wired ready for connection, including drilling template, eyebolt and assembly parts.



Model No. SK with Comfort controller	3301.800
Rated operating voltage V, Hz	230, 50/60
Dimensions in mm	WHD 515 x 400 x 990
Useful cooling output \dot{Q}_K to DIN 3168	L 35 L 35 3000 W/3200 W L 35 L 50 2400 W/2550 W

Rated current max.	10.7 A/10.2 A
Start-up current	19.0 A/19.0 A
Pre-fuse gG	Motor circuit breaker 10.0 A/10.0 A
Power consumption P_{el} to DIN 3168	L 35 L 35 1200 W/1500 W L 35 L 50 1400 W/1750 W
Refrigeration factor $\epsilon = \dot{Q}_K/P_{el}$	L 35 L 35 2,5
Refrigerant	R134a, 1,800 g
Permissible operating pressure p. max.	25 bar
Temperature and setting range	+20°C to +55°C
Protection category to EN 60 529/10.91	External circuit IP 34 Internal circuit IP 54
Duty cycle	100 %
Type of connection	Pluggable terminal strip
Weight	80 kg
Air throughput of fans	External circuit 2000 m ³ /h Internal circuit 1420 m ³ /h
Temperature control	Basic or Comfort controller (factory setting +35°C)

Accessories	Packs of		Cat. 31, page
Filter mats	3	3286.600	668
Metal filters	1	3286.610	669
Quick-change frame	1	3286.900	665
Door-operated switch	1	4127.000	956
SK bus system for Comfort controller	1	3124.100	663
RiDiag II including cables for Comfort controller	1	3159.100	1063
Interface card for Comfort controller	1	3124.200	662
Air ducting system	1	3286.970	658
Cover stoppers for interior air outlet	2	3286.980	658
Condensate hose	1	3301.612	665

Delivery times on request. Special voltages available on request. Technical modifications reserved.

CMC-TC wireless sensor network

Increasingly complex IT infrastructures demand innovative security systems. Rittal offers a wireless sensor network for wireless security. The sensors are encrypted and operate in the 2.4 GHz ISM band with innovative chirp technology.

Thanks to the CMC-TC system concept, all security-relevant information may be incorporated into the network management system or is available on the intranet/Internet.

Benefits:

- Cabling to the sensor is eliminated
- Large range of applications thanks to high IP protection category and temperature range
- Secure, encrypted radio transmission
- ISM band (2.4 GHz) suitable for universal use
- Networking capabilities (TCP-IP, SNMP, Web etc.) with the CMC-TC monitoring system
- Flexible, modular design
- Maintenance-free with long battery operating period
- Simple installation based on the plug & play system
- Monitoring of the radio connection to the sensor
- Monitoring of the battery status

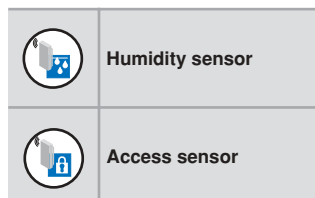
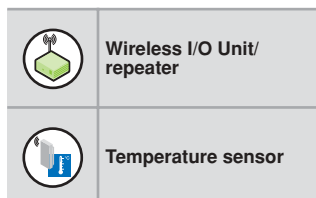
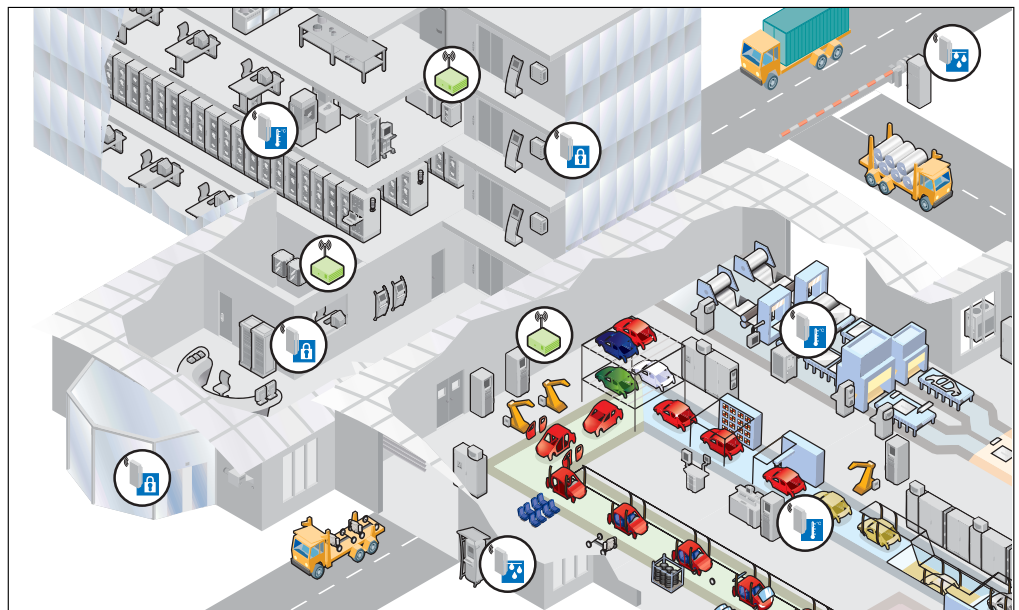

Modular

The wireless sensor network is comprised of a central Wireless I/O Unit, and the wireless sensors. One Wireless I/O Unit is capable of managing up to 16 wireless sensors via radio. Users can choose between 4 sensors with different monitoring functions, in any given combination.

The wireless sensor network is compatible with the CMC-TC monitoring system, which is based on Processing Unit II (PU II). Several Sensor Units (I/O Unit, Access Unit, Climate Unit, FCS, socket strips, etc.) are available for the PU II. Up to 4 sensor units may be connected to one PU II.

The Wireless I/O Unit is connected to the PU II via a Cat 5 cable and can also be mixed with the existing sensor units. Up to a maximum of 4 Wireless I/O Units may be connected to one PU II. In total, therefore, up to 4 x 16 wireless sensors may be operated with one PU II. The CMC-TC system with the PU II is always required in order to operate the wireless sensor network. In this way, the monitoring information may be processed and displayed in the Ethernet via SNMP, Web, FTP etc. It is also possible to connect cabled sensors to wireless sensors and compile modular, application-specific monitoring functions.

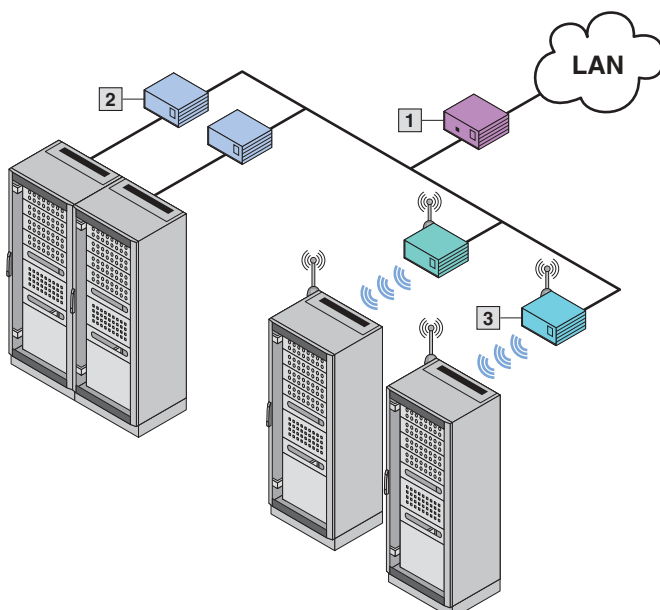

- 1 Processing Unit II (PU II)
- 2 Sensor Unit
- 3 Wireless I/O Unit

Security

CMC-TC wireless sensor network



The wireless access sensor reports any unauthorised access.



The sensors may be protected from humidity via the IP protective cover.



The modular CMC-TC system allows security solutions to be compiled individually, including the use of wireless sensors.

Flexible

The use of radio sensors is appropriate whenever direct cabling between the sensor and I/O Unit is too time-consuming or too difficult to implement, e.g. for outdoor cabling, or in inaccessible places in the server rack or within the IT infrastructure of data centres (indoors). This eliminates the need for cabling, and the system is easily retrofitted while operational. There is no need to lay any cable trunking or modify the IT infrastructure. The position of the measuring point may also be altered retrospectively by simply moving the sensor.

By connecting the Wireless I/O Unit to the existing CMC-TC monitoring system, the system may be extended in a modular and flexible manner. In order to optimise radio links, an external aerial may optionally be used on the Wireless I/O Unit. Similarly, the transmission and reception range may be flexibly extended using additional Wireless I/O Units as repeaters.

Plug and play compatibility system

The wireless sensor network is easily set up using plug & play installation.

By means of a simple commissioning procedure comprised of a learning mode and learning key, the sensors are taught by the Wireless I/O Unit via plug & play. Rittal offers a wireless measurement system with digital display for identifying the optimum radio connection for the assembly site. This measurement system has the same design as the sensors and may be connected to the reference location of the sensor for test purposes.

Robust

The wireless sensor network may be used in racks, bayed enclosure suites, IT rooms, buildings, production plants, storage halls, industrial plant or outdoors. It is also suitable for use in inter-disciplinary applications.

The Wireless I/O Unit and the CMC-TC monitoring system must be installed in a Rittal enclosure with a corresponding protection category to suit the application. The sensors may be used with the IP protective cover.

Long service life

The wireless sensors have a high-capacitive, long-life 3.6 V lithium primary cell. Depending on the sensor type, application and ambient temperature, a battery life of up to 5 years is achievable. The battery cell is continually monitored by the system. It is also possible to replace the battery.

Thanks to the modern chirp radio transmission system, an exceptionally low level of energy consumption is achieved; while in sleep mode, the current rating is in the micro-ampere range, thereby facilitating a long battery life.

Secure

Radio transmission occurs within the ISM band of 2.4 – 2.48 GHz, which is not subject to licensing by the end user.

Using so-called chirp impulses (broadband transmission) for radio transmission produces a high level of protection from interference with other radio systems on the same frequency range, such as WLAN, ZigBee, Bluetooth. Additionally, the integral encryption of radio telegrams offers a suitable level of protection from unauthorised monitoring of the data transmission.

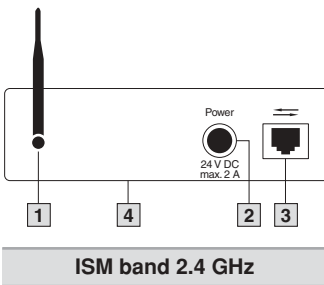

Wireless I/O Unit

The Wireless I/O Unit forms the basis of the Rittal wireless sensor network. For operating purposes, the unit must be cabled to Processing Unit II (PU II) DK 7320.100. This can be achieved via the connection cables for sensor units or via a Cat 5 cable (max. 50 m). Data exchange and power supply to the Wireless I/O Unit occurs via this connection. Up to 4 Wireless I/O Units may be connected to one PU II.

The Wireless I/O Unit has an aerial attached to the enclosure which may be directed according to the installation position. This aerial may optionally be replaced with an external version. The external aerial is available separately as an accessory. The system is attached via the 1 U mounting unit or the individual mounting unit.

A Wireless I/O Unit is capable of managing up to 16 wireless sensors. There is a choice of 4 different sensor types. These are also available as accessories. The sensors may be used in any given combination.

The sensors are commissioned using the button on the Wireless I/O Unit and the sensor button. The wireless measurement system should be used to determine adequate radio connection quality.

Option for a wider reception range:

If the radio range of the Wireless I/O Unit connected to the PU II is not adequate, additional Wireless I/O Units may be used as repeaters (maximum of 10 repeaters). These I/O Units used as repeaters do not require any further cable connection to the PU, but merely need to be supplied with power via a separate power pack with country-specific connection cables.

- 1** Standard system aerial
The external aerial DK 7320.241 may optionally be connected here.
- 2** Socket for power supply to the I/O Unit as repeater. The power pack output DK 7320.425 is connected to this socket. A country-specific connection cable should be used at the primary end (not necessary if the Wireless I/O Unit is connected directly to the PU II).
- 3** RJ 45 connection to PU II 7320.100 via connection cable 7320.470/.472/.481.
The unit is also supplied with power via this connection. A separate power pack is not required.
- 4** Mounting attachments
For attachment with individual mounting unit DK 7320.450 or 1 U mounting unit 7320.440.

	Model No. DK
Wireless I/O Unit	7320.240

Technical specifications:

Range in rooms:
up to 50 m¹⁾
Range in the open with visual connection:
up to 200 m¹⁾
Rated voltage: 24 V DC
1 port RJ 45 for the PU II
16 wireless access points for Rittal wireless sensors
Protection category: IP 40 to EN 60 529
Temperature range: +5°C to +45°C

¹⁾ If the ranges are not adequate, they may be extended with the Wireless I/O Unit as repeater or with the external aerial. The range information depends on the conditions of use and may vary according to the application.



Accessories:

Description	Model No. DK
CMC-TC Processing Unit II – the basic system for the CMC-TC application	7320.100
CMC-TC 1 U mounting unit for the attachment of WL I/O Unit	7320.440
CMC-TC individual mounting unit for the attachment of WL I/O Unit	7320.450
CMC-TC connection cable sensor unit 0.5 m for connecting to the PU II	7320.470
CMC-TC connection cable sensor unit 2 m for connecting to the PU II	7320.472
CMC-TC connection cable sensor unit 10 m for connecting to the PU II	7320.481
CMC-TC power pack 24 V, input 100 – 230 V AC, only for the repeater application of the WL I/O Unit	7320.425
CMC connection cable D 230 V AC for the power pack	7200.210



External aerial

The external aerial may be used in exchange for the standard aerial of the Wireless I/O Unit. If a Wireless I/O Unit is used in a shielded area, improved radio connection to the wireless sensors can be achieved by altering the mounting position of the external aerial. The connection cable supports flexible positioning. The base of the external aerial is equipped with a magnet to facilitate mounting on metal.

	Model No. DK
External aerial	7320.241

Available on request: Outdoor aerial.

Technical specifications:

Length of aerial: 240 mm
Connection cable: 1.5 m
Protection category: IP 40 to EN 60 529
Temperature range: -20°C to +65°C

CMC-TC wireless sensor network



Wireless measurement system

The wireless measurement system has a digital display with a display range from 0 to 9. The reading on the display indicates the quality of the radio connection. The wireless measurement system has the same design as the wireless sensors. This means that the measurement system may be fitted instead of sensors, in order to assess the quality of the radio connection.

A measurement system should be available when commissioning the wireless sensor network. After commissioning, the measurement system may be used for further installations, e.g. during system expansions or modifications. The wireless measurement system has a long-life 3.6 V lithium primary cell. The battery may be replaced if necessary.

	Model No. DK
Wireless measurement system	7320.242

Technical specifications:

Rated voltage: 3.6 V DC
Protection category: IP 40 to EN 60 529
Temperature range: +5°C to +45°C



IP protective cover

for wireless temperature/humidity/access sensor

The IP protective cover allows the IP protection category of the following sensors to be increased:

- Wireless temperature sensor DK 7320.505
- Wireless humidity sensor DK 7320.515
- Wireless access sensor DK 7320.535

The corresponding IP protection categories are listed for the sensors.

The cover is made from flexible plastic and simply slides over the enclosure of the sensor. This gives the wireless sensors protection from humidity plus increased protection from dust.

	Model No. DK
IP protective cover	7320.245



Wireless digital input

The wireless digital input is used for monitoring messages from external systems. It may be operated with the Wireless I/O Unit. In the event of status changes, a message is sent to the central wireless base system. The digital input is capable of handling message signals of between 10 – 30 V DC.

The signal must be made available via the external system. If the system to be monitored only has a floating contact, the 24 V DC Rittal CMC-TC power pack may be used. The 10 – 30 V DC message signal must always be provided externally. The function Normally Open (NO) (normally open alarm contact) or Normally Closed (NC) (normally closed alarm contact) may be selected in the software of the CMC-TC system. The sensor contains a long-life 3.6 V lithium primary cell. The battery may be replaced if necessary. It is mounted using the mounting bracket enclosed with the supply which may be secured e.g. to the enclosure frame. The sensor is simply mounted on the bracket. The battery and the radio connection quality of the sensor are monitored.

	Model No. DK
Wireless digital input	7320.585

Technical specifications:

Rated voltage: 3.6 V DC
External message signal: 10 – 30 V DC (must be provided externally)
Protection category: IP 40 to EN 60 529
Temperature range: +5°C to +45°C
Battery service life:
up to 5 years at –5°C to +25°C¹⁾

¹⁾ Depending on the temperature range and alarm frequency.

Optional accessories

for wireless digital input:

CMC-TC power pack 24 V, input 100 – 230 V AC for external signal

Model No. 7320.425

CMC connection cable D 230 V AC for power pack

Model No. 7200.210

CMC-TC wireless sensor network



Wireless temperature sensor

The wireless temperature sensor is required for monitoring temperatures. It may be operated with the Wireless I/O Unit. Every 60 seconds, a measurement is sent to the central wireless base system. The temperature sensor is accommodated behind a protective membrane and contains a long-life 3.6 V lithium primary cell which may be replaced if necessary. It is mounted using the mounting bracket enclosed with the supply which may be secured e.g. to the enclosure frame. The sensor is simply mounted on the bracket. If a higher IP protection category is required, the sensor may be retrofitted with the IP protective cover. The battery and the radio connection quality of the sensor are monitored.

	Model No. DK
Wireless temperature sensor	7320.505

Technical specifications:

Rated voltage: 3.6 V DC
 Protection category: IP 40 to EN 60 529
 Protection category with protective cover: IP 54 to EN 60 529
 Temperature range: -25°C to +65°C
 Measurement tolerance: ±2°K
 Battery service life: up to 5 years at -5°C to +25°C¹⁾

¹⁾ Depending on the temperature range.



Wireless humidity sensor

The wireless humidity sensor is used for monitoring relative humidity levels. It may be operated with the Wireless I/O Unit. Every 120 seconds, a measurement is sent to the central wireless base system. The humidity sensor is accommodated behind a protective membrane and contains a long-life 3.6 V lithium primary cell which may be replaced if necessary. It is mounted using the mounting bracket enclosed with the supply which may be secured e.g. to the enclosure frame. The sensor is simply mounted on the bracket. If a higher IP protection category is required, the sensor may be retrofitted with the IP protective cover. The battery and the radio connection quality of the sensor are monitored.

	Model No. DK
Wireless humidity sensor	7320.515

Technical specifications:

Rated voltage: 3.6 V DC
 Protection category: IP 40 to EN 60 529
 Protection category with protective cover: IP 54 to EN 60 529
 Temperature range: -25°C to +65°C
 Measuring range: 10 – 90 % relative humidity.
 Measurement tolerance: ±3 % rel. hum. (at 20°C)
 Battery service life: up to 5 years at -5°C to +25°C¹⁾

¹⁾ Depending on the temperature range.



Wireless access sensor

The wireless access sensor is used for monitoring doors. It may be operated with the Wireless I/O Unit. In the event of a status change, a message is sent to the central Wireless I/O Unit. The access sensor is equipped with a Hall sensor which monitors the position of the magnet on the door. The sensor contains a long-life 3.6 V lithium primary cell; the battery may be replaced if necessary. It is mounted using a mounting bracket and a universal mounting bracket for various Rittal racks. The sensor is simply mounted on the bracket. If a higher IP protection category is required, the sensor is easily retrofitted with the IP protective cover. The battery and the radio connection quality of the sensor are monitored.

	Model No. DK
Wireless access sensor ²⁾	7320.535

²⁾ Brackets included

Technical specifications:

Rated voltage: 3.6 V DC
 Protection category: IP 40 to EN 60 529
 Protection category with protective cover: IP 54 to EN 60 529
 Temperature range: -25°C to +65°C
 Battery service life: up to 5 years at -5°C to +25°C¹⁾

¹⁾ Depending on the temperature range and door opening frequency.

Monitoring system CMC-TC Master II



USB web camera available on request.

Monitoring system CMC-TC Master II

Benefits:

- Centralised administration
- Network connection 10/100BaseT
- Central web server for configuration
- Local administration via console VGA/PS/2
- Logging function for alarm messages
- Link for USB web camera
- Free function selection for monitoring
- Ideal for large data centres
- Web access via SSL 3.0
128 bit encryption
- Remote administration via SSH
- Monitoring functions may be linked together
- E-mail function via SMTP
- Video monitoring may be linked to the CMC-TC monitoring functions

The CMC-TC Master II is an optional component in the CMC-TC system. The master allows the alarm data of up to 10 PU II systems to be linked and displayed. Special features of this system include its superior flexibility and performance. Up to 10 PU II systems may be distributed directly in the customer's intranet. Like the PU II, the Master II may be placed at any position within the network.

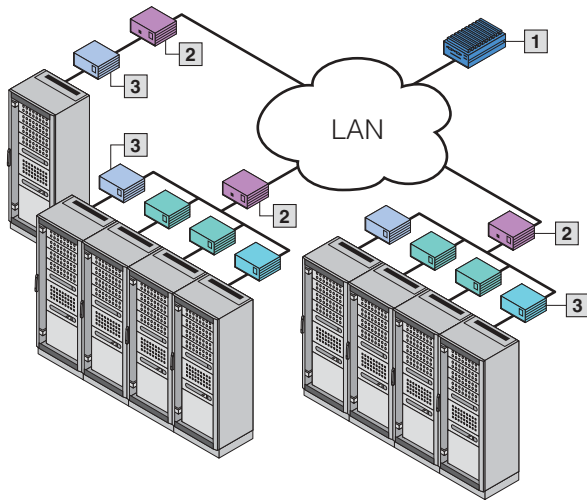

- 1 Master II
- 2 Processing Unit II (PU II)
- 3 Sensor Unit

It is possible to directly access the web pages of the PU II or the web page of the Master II, where all data is combined and linked. The PU II transmits all monitoring-related data and messages to the master system via TCP/IP, SNMP. The master unit has a 10BaseT/100BaseT network interface for network integration.

All monitoring data is provided in a separate MIB via TCP/IP, SNMP. The system may be configured remotely via the integral web server. Basic settings can also be implemented serially via RS232 or Telnet. A Telnet routing function to the individual Processing Units II is also pre-integrated. This provides the user with a clear central monitoring facility. For example, up to 160 temperature sensors may be accessed or up to 80 enclosure doors may be monitored and activated via one IP address. Combined applications are also possible, and may be compiled individually from PU II and sensor units. Functional upgrades for the CMC-TC Master II are available on request in the form of a software update. Images may be archived on the hard drive via an optional web camera. Up to two USB cameras may be connected. USB webcam available on request.

Model No. DK	7320.005
Network interface	Ethernet to IEEE 802.3 via 10BaseT/100BaseT, 10/100 Mbit/s
Protocols	TCP/IP, SNMP V1.0, TELNET, SSH, TFTP, HTTPS

Rated voltage	100 – 240 Volt AC, 50/60 Hz
Serial interfaces	2 D-SUB 9 jacks RS232
USB	Standard 2.0 for Rittal USB webcams
Time function	Real-time clock
Temperature application range	+5°C to +35°C
Humidity application range	5 % to 80 % relative humidity, non-condensing



Also required:

A component shelf must also be ordered for each CMC-TC Master II, see page 22.

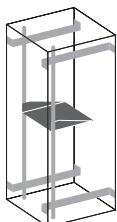

Component shelf

for attachment of the CMC-TC Master II
The 2 U component shelf serves to accommodate the CMC-TC Master II in a 482.6 mm (19") rack.

Depth:
400 mm

Load capacity:
25 kg surface load, static

Material:
Sheet steel

Colour:
RAL 7035

Component shelf	Model No. DK
2 U	7119.400

Monitoring system Processing Unit II



CMC-TC monitoring system Processing Unit II (PU II)

The Processing Unit II (PU II) is the central control of the CMC-TC system. This unit is required for every monitoring application in the CMC-TC system. The PU II contains a powerful computer with modern network technology. On the basis of the PU II hardware (hardware version 3.01), new software functions may be utilised via the update routine. These applications are listed below.

The update software with new software functions may be downloaded from www.rimatrix5.com

	Model No. DK
Processing Unit II	7320.100

Ethernet to IEEE 802.3 via 10/100BaseT full duplex is available as the network interface. The basic protocols are TCP/IP, SNMPv1, Telnet, FTP, HTTP, HTTPS, NTP, SSH, DHCP. Rittal sensors, door systems, fans, climate control units, extinguisher systems, LCP air/water heat exchangers and socket strips may be connected as applications.

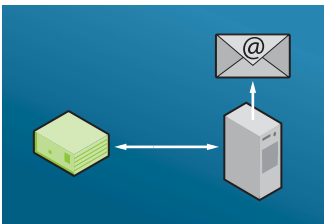

Simple Mail Transfer Protocol (SMTP)

The new PU II update software supports the sending of e-mails via SMTP in the event of an alarm. If an SMTP e-mail server is operated in the user network, the PU II is able to send alarm e-mails

via the server. The e-mails contain the date, time, system name, system location, system contact and alarm text. The PU II may be operated with or without authentication for SMTP.

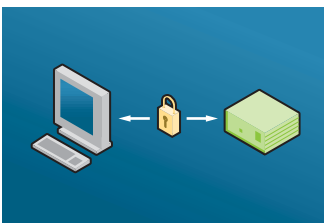

Secure File Transfer Protocol (SFTP)

The PU II supports the protocol FTP. This means that the log alarm file or access code list may be transmitted from and to the PU II. The files may be transmitted in encrypted form for added security.

The new PU II update software supports SFTP (SSH). This means that sensitive data content is protected during transmission.

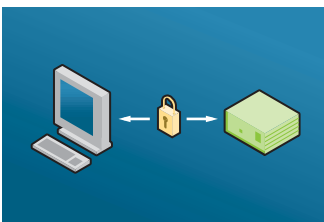

Simple Network Management Protocol (SNMPv3)

The PU II supports the protocol SNMPv1. With this protocol, data from the security system may be polled, limits set, and a trap alarm system implemented. SNMP is the most important interface from the PU II to the user with a network management system (NMS). In order to improve security, Rittal has integrated the protocol SNMPv3 with the new PU II update software. The protocol may be

used in conjunction with a network management system (NMS) with SNMPv3 support. The SNMPv3 specifications were approved as a full Internet Standard in March 2002 by the Internet Engineering Steering Group (IESG). The SNMPv3 specifications essentially add security and remote configuration capabilities for SNMP.

Accessories for the CMC-TC system



CMC-TC leak sensor, 15 m

The leak sensor is able to detect electrically conductive fluids such as freshwater, salt water, glycol solutions etc. over a distance of 15 m. The sensor may be fitted underneath water pipelines, LCP applications, climate control applications in bayed enclosure suites etc., preferably on the floor. Attachment on or close to the floor allows the system to detect even tiny quantities of fluid. The sensor may be connected directly to the I/O Unit using the patch cable supplied loose via plug & play. The sensor contains an identifier, allowing it to be automatically detected and set up by the CMC-TC system.

The 15 m long sensor cable is connected to an enclosure with the evaluation electronics via a 3.5 m long connection cable. The enclosure must be correctly installed according to the IP protection category, e.g. in a Rittal rack. The sensor cable is colour-coded to distinguish it from other cables in the monitoring area. The carrier material PEHD is chemically neutral with long-term stability. The PHLD sensor cable is very robust and protects the measurement wires inside from damage and accidental activation. The sensor cable is liquid-repelling and can therefore be quickly reused following a leak.

	Model No. DK
Leak sensor	7320.631

Extended delivery times.

To fit Sensor Unit:

I/O Unit	Access Unit	Climate Unit
■		

Technical specifications:

Monitoring: Conductive sensor cable
 Length of sensor cable: 15 m
 Connection cable to electronics: 3.5 m
 Patch cable to I/O Unit: 2 m
 Rated voltage: 24 V DC
 Protection category of electronics with enclosure: IP 40 to EN 60 529
 Temperature range: +5°C to +45°C



CMC-TC acoustic anti-vandalism sensor

The CMC-TC acoustic sensor may be used in all situations where protection from vandalism is required. The sensor responds to loud mechanical noises such as those associated with a break-in. The sensitivity of the sensor is adjustable. The sensor contains an identifier allowing it to be automatically detected and set up by the CMC-TC system.

	Model No. DK
Acoustic sensor	7320.640

Extended delivery times.

To fit Sensor Unit:

I/O Unit	Access Unit	Climate Unit
■		

Technical specifications:

Sensor: Microphone
 Frequency range: 50 Hz – 10 kHz
 Noise level: 60 – 100 dB (A)
 Response time: 20 ms
 Patch cable to I/O Unit: 2 m
 Rated voltage: 24 V DC
 Protection category of electronics with enclosure: IP 40 to EN 60 529
 Temperature range: +5°C to +45°C



Rack extinguisher system DET-AC Plus, 1 U

With integral early fire detection

This compact rack extinguisher system DET-AC Plus (Detection Active Plus) is designed for use in the Rittal IT rack, fitted in the 482.6 mm (19") level. The system is equipped with a 2-stage smoke analysis extractor system. A bayed rack may optionally be included in the monitoring and extinguisher system. The system is also suitable for use in racks with bayed air/water heat exchangers (Liquid Cooling Package, LCP). The eco-friendly, non-toxic Novec¹⁾ 1230 is used as the extinguisher medium, which means that this extinguisher system is suitable for universal use. Undamaged, active hardware (servers, active network technology) is not impaired by the extinguisher medium.

Thanks to the extremely sensitive detection of smoke, even in racks with a high level of climate control (airflow speed), this ensures that there is plenty of time to forward an alarm message either acoustically, optically via the LC display on the enclosure front, or by connecting the integral floating contacts to the building management system or fire alarm centre and to the Rittal monitoring system CMC-TC. When opening an enclosure door, activation of the extinguisher system is blocked by the two access sensors (door monitoring).

In order to ensure that proper functioning of the system is maintained even in the event of a power failure, an emergency back-up power supply with a stored energy time of 4 hours is integrated into the system.

The system can also be supplied purely as an early fire detection system without the extinguisher medium tank.

¹⁾ Novec is a registered trademark of 3M.

Early smoke detection:

Thanks to the two highly sensitive optical sensors, minute particles of smoke may be detected even in the early stages of a fire (pyrolysis phase) via the active smoke extraction. If the 1st alarm detects smoke aerosols, a pre-alarm is triggered, and if the 2nd alarm likewise detects smoke, the extinguisher system is activated. This prevents major fires from developing.

Rack requirements:

As a general principle, the racks must meet protection category IP 55, i.e. with sealed doors and screw-fastened side panels. Use of an air/water heat exchanger (LCP) is supported.

Optional smoke analysis, extension for bayed racks:

The basic DET-AC Plus system is designed for a single rack, but neighbouring enclosures may also be incorporated via an additional pipe kit, provided the total interior enclosure volume to be extinguished does not exceed 3 m³. Several extinguisher systems may also be linked together in the bayed enclosure suites, so that all systems may be activated jointly.

Automatic system deactivation (compulsory deactivation):

In conjunction with the Rittal enclosure monitoring system CMC-TC plus suitable switchable Rittal socket strips (Power System Module PSM/Power Control Unit PCU with active current measurement, display and switching options), in the event of an alarm, compulsory deactivation of the components installed in the rack may be triggered. This ensures that the servers are protected from further destruction.

The alarms (pre-alarm, main alarm) may be transmitted via any given IP networks and processed in corresponding monitoring programs. The extinguisher system is supplied complete with mounting accessories.

Technical specifications:

Protection/rack volume: 3.0 m³
 Extinguisher medium: Novec¹⁾ 1230
 Weight of extinguisher medium: 3.2 kg
 Power supply: 115 – 230 V AC/50 – 60 Hz
 Emergency power supply (integral battery): max. 4 h
 Contact rating (pre-alarm, alarm, blocking): max. 30 V DC/1 A
 Sensors: 2x sensitive sensors, one each for pre-alarm/main alarm
 Ambient temperature: 10 – 35°C
 Display: LCD display with plain text information
 Protection category: IP 30
 Material of enclosure: sheet steel, spray-finished
 Material of extinguisher tank: Aluminium
 Dimensions (W x H x D): 447 x 1 U x 780 mm

Description	Packs of	Model No. DK
DET-AC Plus extinguisher system with early fire detection	1	7338.100
DET-AC Plus early fire detection	1	7338.200
DET-AC pipe kit for bayed rack	1	7338.310

Also required:

CMC-TC access sensor (only with extinguisher system)	2	7320.530
Mains connection cable (earthing-pin, German)	1	7200.210

Delivery times available on request.

Note:

The extinguisher system must be installed and maintained by qualified experts. Rittal is happy to offer such a service.

When buying several different IT racks together, a combined enclosure interior volume of 3 m³ must not be exceeded!

Enclosure interior volume of popular Rittal IT racks

Width mm	Height mm	Depth mm	Enclosure interior volume per rack/m ³
300	2000	1000	0.6
300	2000	1200	0.72
600	2000	1000	1.2
600	2000	1200	1.44
600	2200	1000	1.32
600	2200	1200	1.584
800	2000	1000	1.6
800	2000	1200	1.92
800	2200	1000	1.76
800	2200	1200	2.112

Extinguisher system for use in 800 mm deep racks available on request.

Monitoring

Video technology

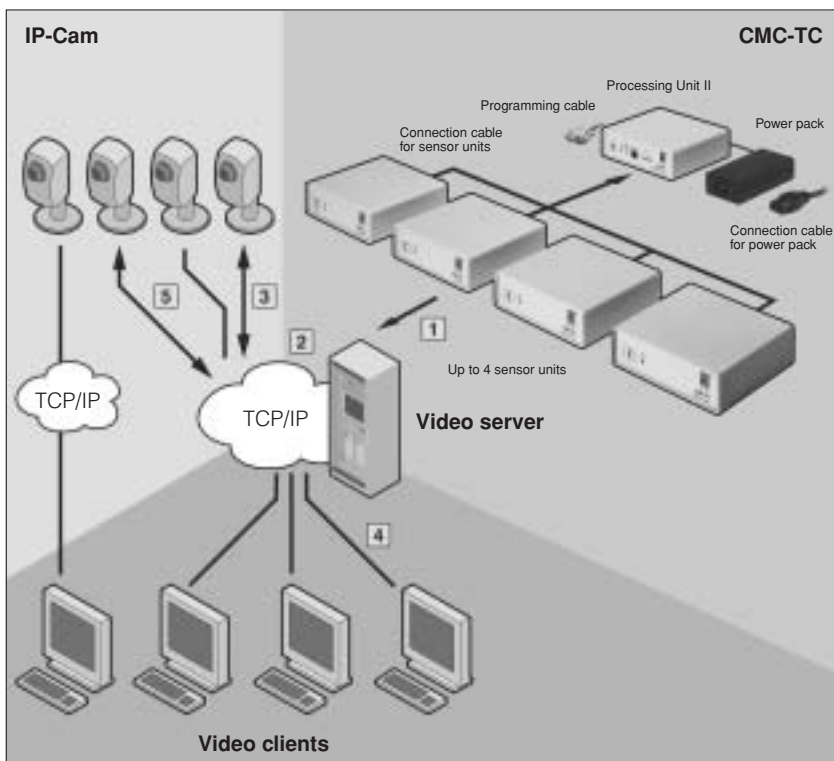

- 1 Event messaging
- 2 CMC-TC alarm processing
- 3 Start recording
- 4 Client visualisation
- 5 Motion detection

Rittal network video monitoring for your data centre and building management

The Rittal IP monitoring solution supports extensive visual and alarm-controlled monitoring. Unlike standard analog video monitoring solutions, digital video systems offer a more extensive range of functions and additional benefits. Rittal IP-Cams may be integrated into any existing network. Separate structured cabling, as required in analog systems, is not necessary. This considerably reduces the costs associated with the required infrastructure, because modern Power over Ethernet technology (PoE to IEEE 802.3af) means that a separate power supply to the camera installation side is not required.

The Rittal video monitoring system is modular and is able to grow dynamically along with your requirements or data centre. One IP-Cam is sufficient for a basic system. This is easily configured and operated via the integral Web interface, on request even worldwide. No further hardware is required. If the data is to be permanently backed up onto external data carriers, the Rittal software RiWatchIT "Video Edition", which is exclusively available for Rittal IP-Cams, should be used. This converts a powerful PC with MS Windows or Linux operating system into a video server with video archive, which stores alarm-controlled images onto the hard disk or an external network drive. A combination of video monitoring with the CMC-TC enclosure monitoring system ensures even more extensive monitoring. This ensures that no actions are concealed. All standard CMC-TC sensors such as access, smoke or temperature sensors are supported. In short, the Rittal video monitoring solution affords perfect all-round protection for a secure data centre.

Video monitoring in combination with the CMC-TC monitoring system

The Rittal monitoring system CMC-TC comprises a broad range of modules and functions. It is possible, for example, to control access to the data centre or the equipment racks, with personalised access monitoring achieved by way of smart-cards, magnetic cards or transponders. This access security can be enhanced significantly by incorporating video monitoring, as all activities or alarms in the data centre can be recorded automatically.

Furthermore, the video monitoring function can be linked with all CMC-TC accessory sensors (including the assignment of different camera systems). If an alarm then occurs, e.g. impermissible temperatures in the racks or triggering of an extinguisher system connected to CMC-TC (such as DET-AC Plus), an automatic video recording is started. With this combination of active security technology and video monitoring, Rittal offers unique, all-round protection for your data centre.



Benefits:

- Discovery function: The cameras installed in the network are automatically detected and set up.
- Overview/room plan with drag & drop positioning of the cameras. By double-clicking on the relevant camera symbol, the live image is displayed in a window.
- Linking of individual cameras to all CMC-TC sensors such as access, temperature, smoke, humidity etc.
- Optical alarm representation with highlighted live image.
- Multi-view display: Several live images (4/9) may be displayed on the screen.
- The software has an integral video player to play the recorded files.
- All video files are time stamped and stored in MJPEG format.

- Extensive security functions:
 - The video files are stored in an encrypted format via an individual system key. Reproduction is only possible using the video player integrated into the software.
 - "Four-eyes" principle: Upon request, access to the cameras and video recordings may be protected with passwords, so that at least two people must be present at all times.
- Export functions: These facilitate the unencrypted storage of video sequences or individual images in MJPEG/JPG format e.g. on CD-ROM.
- Multi-config in administrator mode: Global camera settings may be transmitted to all Rittal IP-Cams available in the network (clone function).
- Simultaneous access to the video server with several clients is supported.



Rittal IP-Cams type 1 and type 2

Rittal IP-Cams are ideal for use in the data centre and for indoor room monitoring. These compact cameras may be fitted quickly and easily wherever there is an IP network connection close at hand.

The magnetic base facilitates toolless installation e.g. on an enclosure roof. The two camera models available are distinguished primarily via the video resolution and PoE (Power over Ethernet capabilities).

Rittal IP-Cams	Type 1	Type 2
Model No. DK EU version	7555.100	7555.200
Functions		
Video sensor (MegaPixel)	0.3	1.3
Focus	manual	manual
Video		
Live camera display	■	■
Adjustable HTML pages (ActiveX required)	■	■
Security functions		
Alarm recording via motion detection or external authorisation	■	■
E-mail forwarding	■	■
Technical specifications		
Video sensor	CMOS	CMOS
Light sensitivity	1 lux	1 lux
Maximum resolution (progressive scan)	640 x 480 pixels	1280 x 1024 pixels
Video streams Motion JPEG and MPEG4 simultaneous, bandwidth controllable (various compression stages)	■	■
Image settings		
Compression	■	■
Colour, contrast, brightness	■	■
White balance	■	■
Overlays (time, date, text)	■	■
Password protection (restricted access)	■	■
Connections		
Network (10BaseT/100BaseTX)	RJ 45	RJ 45
Power supply	Hollow connector	Hollow connector
Long-range power pack (connector acc. to version)	100 – 240 V AC (50/60 Hz)	100 – 240 V AC (50/60 Hz)
Supply includes	Camera, power pack, base	Camera, power pack, base
Assembly parts supplied loose	■	■

We reserve the right to make technical modifications.



RiWatchIT

Video edition (for Rittal IP-Cams)

This client/server application is the management centre for the Rittal video monitoring system. This software allows several cameras to be monitored, controlled, and on request linked to CMC-TC sensors.

Note:

The RiWatchIT "Video Edition" software can only be used with Rittal IP-Cams (DK 7555.xxx)!

Further information:

www.rimatrix5.com

	Model No. DK
RiWatchIT Video Edition	7555.300

Benefits and functions:

- Cost-effective, because it uses the existing network infrastructure
- Future-proof IP technology
- Flexible use for data centre and indoor building monitoring
- Global access is supported via IP networks
- Scalability – the system grows along with your requirements
- Free monitoring software for Rittal IP-Cams
- Supports a unique link with the CMC-TC sensors
- Choice of two compact camera models
- 16 cameras are supported



SSC Connect

for SSC view 32 Cat/compact 32 Cat

These converters connect the KVM switches to the computers. The signals for keyboard, mouse and video are transposed onto the Cat cables and transmitted to the SSC compact 32 Cat/view 32 Cat up to a length of 30 m. Two versions with PS/2 connection for keyboard/mouse and with USB connection (connector type A) are available. The video signal (VGA) is picked off from the graphics card via a Sub-HD15 connector. Power supply to the converters is ensured via the PS/2 or USB interface directly from the computer.

Technical specifications:

Video resolution: 1600 x 1200 at 85 Hz
Power supply: 5 V DC/approx. 150 mA (from the computer)
Certification: CE
Dimensions: approx. 65 x 45 x 20 mm



Design	Packs of	Model No. DK
SSC Connect PS/2	1	7552.421
SSC Connect USB	1	7552.422

Note:

The SSC Connect cannot be used with the SSC premium KVM system. The SSC converters (DK 7552.20x) are available for this purpose, see Innovations 2005/2006, page 160.



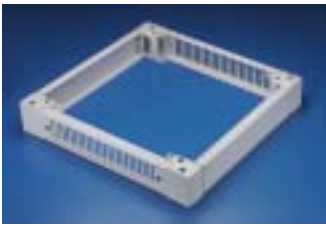

Base/plinth, vented for TE 7000

For easier cable routing between bayed enclosure systems or as additional storage space beneath the enclosure, this vented complete base/plinth is easily screwed underneath. The trim panels may be removed on all sides to allow cable routing in all directions.

Base/plinth height:
100 mm

Material:
Sheet steel, spray-finished

Colour:
RAL 7035/9005

Supply includes:
1 base/plinth, vented
including assembly parts.



For enclosures		Colour RAL	Model No. TS
Width mm	Depth mm		
600	1000	9005	7000.686
800	1000	9005	7000.687
600	600	7035	7000.690
600	800	7035	7000.691
600	1000	7035	7000.692
800	600	7035	7000.693
800	800	7035	7000.694
800	1000	7035	7000.695

+ Accessories:

Filter mat for base/plinth, vented,
600 mm wide DK 7561.500 and
800 mm wide DK 7581.500,
see Cat. 31, page 840.



Base/plinth trim, solid for base/plinth, vented

To be used in exchange for the existing trim panel. If a solid design is required for the base/plinth for TE, the vented front and rear trim panels should be exchanged for solid trim panels.

Material:
Sheet steel, spray-finished

Colour:
RAL 7035

Supply includes:
2 base/plinth trim panels
including assembly parts.

For enclosure width mm	Colour RAL	Model No. TS
600	7035	7000.696
800	7035	7000.698

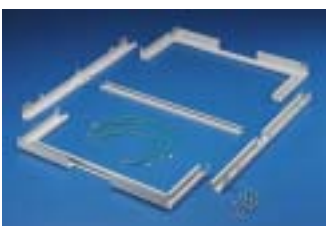

Base frame, divided for server racks DK-TS, FR(i)

For retro-fitting a base frame Particularly for the use of gland plates or base modules within TS server enclosures, it is necessary to fit this base frame first in order to accommodate the base elements. The divided design also allows it to be retro-fitted. Suitable for combining with the pull-out stabiliser.

Material:
Sheet steel, zinc-plated, passivated

Supply includes:
Packs of 1 set
Frame elements
including assembly parts.

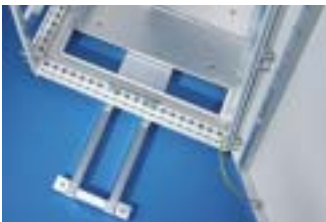

For enclosures		Model No. TS
Width mm	Depth mm	
600	900	7825.341
600	1000	7825.342
600	1200	7825.343
800	1000	7825.344
800	1200	7825.345

Note:

Transport kit:
For optional use of the transport kit TS 7825.900 (see Cat. 31, page 849) the front and rear frame elements may be temporarily removed and then re-fitted to the transport.

Stabiliser:
see Innovations 2005/2006, page 177.

+ Accessories:

Gland plate, multi-piece,
see page 30.

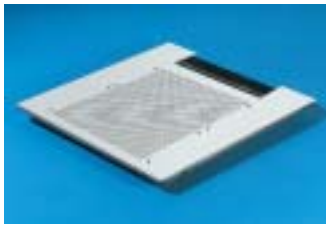

One-piece gland plate

**vented
for TS, FR(i)**

The slotted gland plate has a cut-out in the rear for cable entry, which is concealed with brush strips.

Material:

Sheet steel, zinc-plated, passivated

Supply includes:

Gland plate including assembly parts.

For enclosures		Model No. TS
Width mm	Depth mm	
600	1200	7825.612
800	1200	7825.812



Accessories:

Filter mat for gland plate DK 7825.620, see Innovations 2005/2006, page 177.



Gland plate, multi-piece

for TS, FR(i)

For optional sealing of the base area. Any combination of gland plates is supported. Gland plates including mounting clamps; the additional installation of PE conductors is not required.

Material:

Sheet steel, zinc-plated, passivated

Supply includes:

Packs of 1 set
Gland plates including sliding plate for cable entry, including sealing tape and assembly parts.

Note:

For the size variant 800 x 800 mm, the gland plate included with the supply for pre-configured network enclosures should be additionally used.

For enclosures		Model No. TS
Width mm	Depth mm	
600	900	7825.363
600	1000	7825.364
600	1200	7825.365
800	800	7825.382
800	900	7825.383
800	1000	7825.384
800	1200	7825.385



Also required:

For integration of the gland plates, there must be a base frame inside the enclosure. Base frame, divided, for retro-fitting, see page 29.



Accessories:

All gland plates with a depth of 237.5 mm may be exchanged for gland plate modules on request. Gland plate modules, see Cat. 31, page 851. Gland plate modules, vented with air volume regulator, see below. Base module for cable entry, see page 32. Extrusions for cable entry, see Cat. 31, page 965.

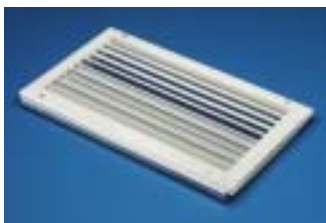

Gland plate modules, vented

**with air volume regulator
for DK-TS, FR(i)**

Allows controlled air routing from the twin base to the installed components. Individually adjustable membranes facilitate control of the air inlet opening between 10 % and 80 % free space.

If the rear area of the enclosure is partitioned by base/gland plates, the required volumetric airflow may be individually regulated, and distribution of the airflow inside the twin base adapted to suit the requirements of each enclosure.

The gland plate module may be combined with all gland plates as required. Gland plate module including contacting assembly screws; the additional installation of PE conductors is not required.

Material:

Sheet steel

Supply includes:

Packs of 1
Gland plate module, vented, filter mat, including assembly parts.

For enclosure width mm	Model No. DK
600	7825.366
800	7825.386



Also required:

For integration of the gland plates, there must be a base frame inside enclosure. Base frame, divided, for retro-fitting, see page 29.



Accessories:

Spare filter mat, see page 31.

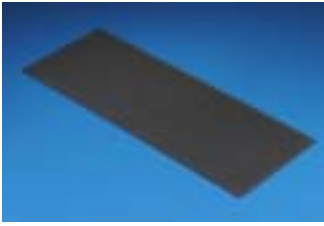

Spare filter mat
for gland plate modules, vented
see Cat. 31, page 851.

To be used in exchange for the existing filter mat.

Material:
PPI 35-15

Supply includes:
2 filter mats
including mounting accessories.

Packs of	Model No. DK
2	7825.350

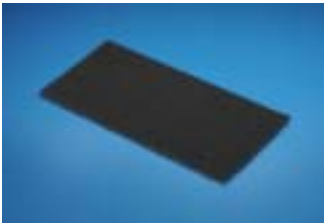

Spare filter mat
for gland plate modules, vented,
with air volume regulator

To be used in exchange for the existing filter mat.
Easily exchanged thanks to front operation via guides.

Material:
PPI 35-5/polyamide

Supply includes:
1 filter mat
including mounting accessories.

Packs of	Model No. DK
1	7825.622



Module plate, solid
for TE

Compensating panels in 2 new sizes.
The base area of the TE may be varied as required using the module plates.

Material:
Sheet steel, zinc-plated, passivated

Supply includes:
Assembly parts.

Design	Width mm	Depth mm	Model No. TE
Compensating panel	450	150	7526.755
	650	150	7526.795

Note:

For a completely sealed base assembly, the module plates should be combined with the compensating panels.

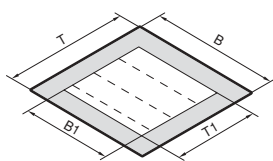

B = Width
T = Depth

Note: New base cut-out dimensions

Enclosure dimensions mm	B	600	600	600	800	800	800
	T	600	800	1000	600	800	1000
Base cut-out dimensions mm	B1	450	450	450	650	650	650
	T1	550	750	950	550	750	950



Base module for cable entry

super-sealed for DK-TS, FR(i)

The two-part base module has a special cable entry with alternate offset brush strips which guarantee an excellent seal even with large cable quantities. This minimises the possible ingress of inappropriate air or the unintentional escape of extinguisher gas or coolant.

The two-part design allows the module plate to be removed at any time, even when cables have already been inserted, to provide access to the level beneath the rack. Base module with contact mounting clamps; the additional installation of PE conductors is not required.



For enclosure width mm	Packs of	Model No. DK
600	1	7825.367
800	1	7825.387

Material:

Module plate: Sheet steel, zinc-plated, passivated
Brush strip: Plastic, UL 94-V0

Supply includes:

Brush strip and assembly parts.



Levelling feet

18 – 63 mm high, with hex socket for baying system TS 8, FR(i)

To compensate for floor irregularities. Particularly in confined spaces, adjustments can be made quickly and easily from the enclosure interior.

Mounting thread: M12
Hex socket: 6 mm
Thread length: 60 mm

Maximum permissible static load:
300 kg/levelling foot

Packs of	Model No. DK
4	7493.100



Also required:

For mounting on the TS base/plinth:
Base/plinth adaptor TS 8800.220,
see Cat. 31, page 849.

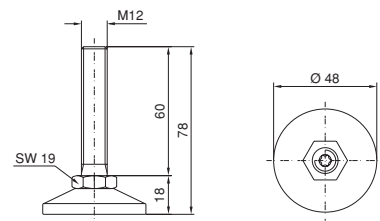

Levelling feet with vibration damping

For vibration insulation of enclosures and to compensate for floor irregularities.

The levelling foot is comprised of a disc of reinforced polyamide and an M12 screw, zinc-plated, with ball joint pendulum plus anti-slip and insulating plate for buffering.

The insulating plate is resistant to water, mineral oils, petrol, alkaline and acid solutions, salts, soap lye and detergents.

Also suitable for special applications such as chemical and laboratory environments.

Thread length: 50 mm

Maximum permissible static load:
150/300 kg per levelling foot

Maximum permissible static load per levelling foot	Packs of	Model No. DK
150 kg	4	7493.210
300 kg	4	7493.230



Also required:

For mounting on the TS base/plinth:
Base/plinth adaptor TS 8800.220,
see Cat. 31, page 849.

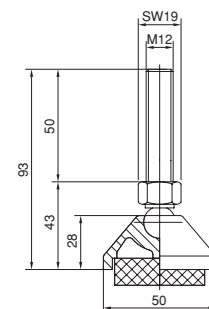



Sheet steel door

for TS

With 180° hinges and swivel handle with security lock no. 3524 E, can be exchanged for comfort handle.

Vented version: For optimum air throughput in network enclosures with a high proportion of active equipment. Slotted surface (SWG-6.7 hexagon) with air inlet openings >78 %.

Material:

Sheet steel

Colour:

RAL 7035

Supply includes:

Assembly parts.

Protection category:

IP 55 to EN 60 529/10.91 (unvented)

IP 20 to EN 60 529/10.91 (vented)

For enclosures		Model No. DK	
Width mm	Height mm	Vented	Solid
800	1200	7824.124	7824.127

+ Accessories:

Comfort handle, see Cat. 31, page 881.
180° hinge for TS bayed enclosure suites with comfort handle, see Cat. 31, page 893.



Designer handle

for DK-TS network and server enclosures

To be used in exchange for the existing handle system. Prepared for the installation of standard commercial semi-cylinders, cylinder length 30/10 mm or 35/10 mm, to DIN 18 254, as well as lock and push-button inserts.

Material:

Die-cast zinc

Surface finish:

Powder-coated

Colour:

RAL 7035

Packs of	Model No. DK
1	7824.600

+ Accessories:

Lock and push-button inserts, see Cat. 31, page 882.
Semi-cylinder with interchangeable lock, see Innovations 2005/2006, page 171.



Mounting adaptor

for designer glazed door, 180°

For the attachment of

- Comfort handle,
- Comfort handle with coded lock or
- Electromagnetic comfort handle

A mounting adaptor is required on the designer glazed door.

This mounting adaptor allows installation of the comfort handle series by simply snapping into position instead of the existing handle system.

Material:

Die-cast zinc

Packs of	Model No. DK
1	7824.610



Hinges 180°

for TS

Now also available in RAL 9005.

For detailed information see Catalogue 31, page 893.

Design	Packs of	Model No. TS
RAL 9005	4	8800.950

System accessories

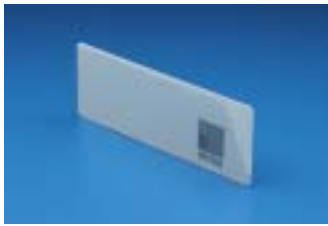

Alternate frame, magnetic

For individual marking or labelling of the existing network infrastructure. The magnetic surface facilitates flexible mounting on all magnetisable surfaces. Adhesive strips are supplied for non-magnetic surfaces. The maximum size of the labels is 130 x 50 mm.

Material:
Plastic

Supply includes:
Alternate frame, magnetic, labels, double-sided adhesive tape.

Packs of	Model No. DK
10	7950.150

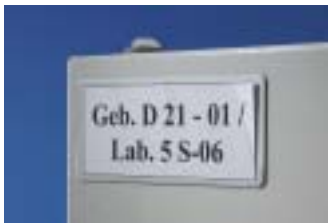

Document clip, magnetic

For simple attachment of installation documentation as a reminder or for flexible accommodation of a wide range of documents, measurement records, test reports etc. May be attached to any magnetisable surface via a permanent magnet.

Material:
Plastic: Transparent
Grips: Black

Supply includes:
2 mounting clamps including permanent magnet.

Packs of	Model No. DK
2	7950.200



Roof plates DK-TS

For mounting:

- TopTherm roof-mounted cooling units
- Vent attachment TS

 The cut-outs in the roof plate are arranged so that the TopTherm roof-mounted cooling units are positioned centrally on the enclosure.

Material:
Sheet steel

Colour:
RAL 7035

For enclosures W x D mm	Suitable for mounting TopTherm	Model No. TS
800 x 800	SK 3273.5XX SK 3384.XXX SK 3385.XXX	8801.920

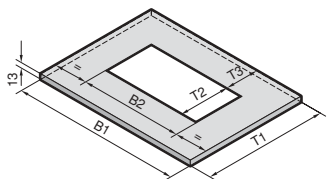

B = Width
T = Depth

For mounting TopTherm	B1 mm	B2 mm	T1 mm	T2 mm	T3 mm	Model No. TS
SK 3273.5XX SK 3384.XXX SK 3385.XXX	767.5	490	767.5	390	161.3	8801.920

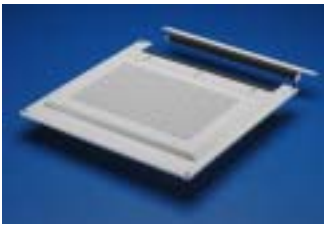

Fan roof, modular, two-piece for TS

Detailed information, see Catalogue 31, page 651.

Technical specifications for one fan:

Rated operating voltage: 230 V
 Power consumption: 15/14 W at 50/60 Hz
 Air throughput (unimpeded airflow): 160/180 m³/h at 50/60 Hz
 Temperature range: -10°C to +55°C

For enclosures		Model No. DK			Fan insert		
		Roof TS	Cover plate				
Width mm	Depth mm	With cut-out	Solid	Vented	Fan insert	Fans wired	Maximum no. of fans
600	1200	7826.362	2102.190	2102.410	2102.490	2	6
800	1200	7826.382	7886.100	7886.200	7886.000	2	8

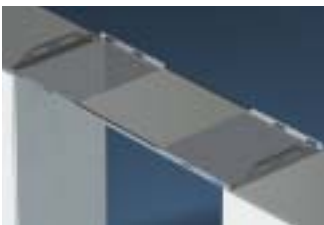

Aisle cover

for server rack series

This aisle cover is used to cover the "cold aisle" between two server racks in data centres. This serves to increase the effectiveness of the sandwich-panel climate control. The expelled cold air is no longer able to escape upwards into the room, and is prevented from mixing with existing warm air. In this way, the cold airflow is available to the active 482.6 mm (19") installed equipment without restriction. The aisle cover is extendible for aisle widths up to a maximum of 1.80 m.

For server racks	Packs of	Model No. SK
600 mm wide	1	3301.430
800 mm wide	1	3301.440



Brush strip, vertical

for TS, TE

Within the network distributor, this serves as a flexible infill panel which stylishly conceals the cable management area to the side of the 482.6 mm (19") mounting level. The brush strip facilitates convenient cable routing from the side and rear distributor area to the front connection level. The clearance required in front of the mounting level is at least 75 mm.

Within the TS, the brush strip is mounted at the side on the vertical frame section, on horizontal or vertical punched sections. It may also be mounted directly on the mounting level of the TS or TE 7000. For direct mounting on the 482.6 mm (19") mounting frame of the TS or TE, the brush strip should be cut to length accordingly.

Material:

Aluminium section with brush strip:
 Plastic, UL 94-V0

Supply includes:

1 set = 4 brush strips,
 length 950 mm each.

For enclosure height mm	Packs of	Model No. DK
2000	1 set	7827.544





Brush strip, super-airtight

For individual installation of enclosure panels, gland plates and panels. Cut-outs for cable routing at any position in the side panel, rear panel, doors, roof and base plate.

These special brush strips may be used to create airtight entries for cable sections and conductors. The brush strips arranged in an offset configuration ensure good sealing from the routed cables even with large quantities of cables. In this way, unwanted system losses may be reduced to a minimum.

Packs of	Model No. DK
2 x 1 m	7825.375

Material:

Brush strip: Plastic, UL 94-V0

Supply includes:

Each 1 brush strip,
1 m in length, right-hand and left-hand version.



Cable routing bars

for 482.6 mm (19") system punchings

For structured cable routing of entire cable bundles, the cable bars may be secured to a variety of different positions inside the enclosure. These routing bar elements are particularly suitable for use in 600 mm wide server racks or in bayed systems where side access is restricted.

Thanks to their open mounting holes, they can also be retrospectively slotted onto the 482.6 mm (19") system punchings of the mounting level at any time and secured with the existing mounting screws of the installed components.

Individual cable routing bars may be extended by buying to create entire systems using a connection comb.

Packs of	No. of connection combs	Model No. DK
1 4	2	7111.224
2 10	5	7111.214

Material:

Support: Sheet steel

Cable routing bars, connection combs: Plastic

Colour:

RAL 9005

Supply includes:

Cable routing bars and connection combs.



1 Cable routing bar, 4 U for 482.6 mm (19") system attachment

For horizontal cable routing within the distributor level.



2 Cable routing bar, 1 U for 482.6 mm (19") system attachment

For cable routing of individual cable bundles within the mounting level or to the installed components.

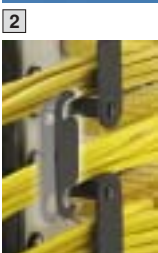

3 Connection comb

For connecting individual cable routing bars into complete systems.



1



2

Cable clamp, variable

for enclosure-independent mounting

Variable attachment of 450 to 800 mm for flexible cable clamping in two variants.

Supports attachment to punched sections with and without mounting flanges and direct screw-fastening onto mounting plates and other flat surfaces.

Material:

Sheet steel, zinc-plated, passivated

Supply includes:

Assembly parts.

1 C rail

2 T-head rail

Design	Packs of	Model No. DK
C rail	1	7016.140
T-head rail	1	7016.150



Cable deflector

for 482.6 mm (19") mounting angles

For kink-free routing of fibre-optic cables from the 482.6 mm (19") level around the mounting angle. The open 482.6 mm (19") attachment facilitates screw-fastening together with the patch panel. The cable deflector may additionally be screw-fastened to the side edge fold.

Material:

Sheet steel, powder-coated in RAL 7035

Supply includes:

1 set =
4 right-hand cable deflectors,
4 left-hand cable deflectors,
Assembly parts
for screw-fastening at the side.

For enclosure width mm	Packs of	Model No. DK
600	1 set	7111.460
800	1 set	7111.480



Snap-in cable routing

for clipping into the system punchings.

Cable routing suitable for universal use, for tool-less, fast assembly, in two variants:

For locking:

- User-friendly opening for cable management via locating points
- For cable diameters 14 – 19 mm
- For system punchings 6.2 mm

For twisting:

- User-friendly opening for cable management
- For cable diameters 10.2 – 12.7 mm
- For system punchings 4.7 mm

Material:

Polyamide 6.6, self-extinguishing to UL 94 V-2

Colour:

Natural

Design	Packs of	Model No. DK
For locking For system punchings 6.2 mm	10	7111.300
For twisting For system punchings 4.7 mm	10	7111.310



Nylon loop cable holder

self-adhesive

Suitable for universal use in all network enclosures and server racks, wall-mounted enclosures, mounting plates and gland plates.

Material:

Woven polyamide 6.6

Colour:

Black

Size length x width mm	Packs of	Model No. DK
70 x 16	10	7111.350



Cover section

for cable duct, designer glazed door, 180°

For optional sealing of the cable duct within the designer glazed door, 180°.

The pack is comprised of various pieces which together are sufficient to seal the cable duct of a door with the dimensions H x W 2200 x 800. Other sizes can be achieved by cutting to length. Connection is toolless by simply clipping into the strip.

Material:

Plastic, RAL 7035

Supply includes:

6 pieces of 1000 mm, for cutting to length and combining.



Packs of	Model No. DK
1 set	7824.850



Blanking panel 1 U

Toolless attachment, 482.6 mm (19")

Now also available in RAL 9005. For further details, see Innovations 2005/2006, page 193.

Packs of	Model No. DK
10	7151.105

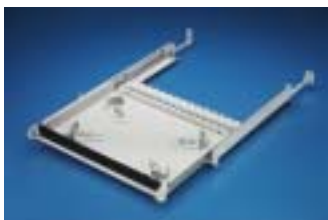

Drawer 482.6 mm (19")

to accommodate excess cable length

The 1 U drawer offers a convenient opportunity for storing excess length in an organised, compact and secure way within the 482.6 mm (19") levels.

- With brush strip at the front for cable entry
- T-head rail in the rear section for cable clamping
- Ring-shaped kink-free routing of the conductors on adjustable elements in the interior
- May be fitted between two 482.6 mm (19") levels at a distance of 435 – 750 mm
- Independent from the enclosure system
- Both on L-shaped and cranked mounting angles and mounting frames.

Material:

Sheet steel

Colour:

RAL 7035

Supply includes:

Assembly parts.



Packs of	Distance between angles mm	Model No. DK
1	435 – 750	7063.200

+ Accessories:

Nylon loop DK 7072.220/DK 7072.230, see Cat. 31, page 982.



Service socket

for enclosure frame attachment

Integration of a service socket within a separate supply circuit, independently of the IT network and UPS.

Simple installation via an angle bracket for attaching to the enclosure frame.

Material:

Angle bracket: Sheet steel, zinc-plated, passivated
Socket: Plastic

Supply includes:

Angle bracket, damp-proof socket (IP 44), German version, including assembly parts.



Packs of	Model No. DK
1 set	7280.100

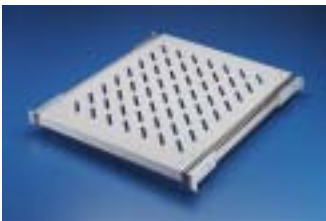

Component shelf, complete set, pull-out

for TE 7000

Tailored to the distance between levels in enclosures as per their supplied state of 495 mm, this complete set contains a vented component shelf, telescopic slides and a mounting kit for direct attachment.

The mounting kit also offers depth-variable attachment within 200 mm with a 25 mm pitch pattern.

Load capacity:

50 kg, static

Material:

Base: Sheet steel, spray-finished in RAL 7035
Mounting kit/telescopic slides: Zinc-plated, passivated

Supply includes:

1 component shelf, telescopic slides and mounting kit.



Base depth mm	Packs of	Model No. DK
500	1 set	7000.625



Accessories:

Handles for component shelf, see Cat. 31, page 953.

System accessories

Voltage supply



Socket strip, 482.6 mm (19")

with optional locking of the cable outlets

The socket strip is constructed from an aluminium channel and is 482.6 mm (19") wide and 1 U high and may be integrated into all standard 482.6 mm (19") enclosures. With this in mind, special attention has been devoted to practical, universal fastening. The universal mounting bracket creates variable mounting opportunities. For example, the 439 mm long socket strip may optionally be mounted on the 482.6 mm (19") mounting angle or on the punched section with mounting flange and enclosure frame.

Additionally, a locking option for the outgoing cables to the equipment has now been integrated. This protects the cables from unintentional loosening, which in turn increases the security and availability of applications.



Design	Model No. DK
12 x C13	7240.600

Technical specifications:

Mains voltage: 250 V
 Rated current: 10/16 A
 Connection cable: 1.5 m

Supply includes:

Socket strip, two mounting brackets including assembly parts.



Accessories:

PSM cable lock,
 see Innovations 2005/2006, page 141.



Socket strips

with ammeter

The socket strip with ammeter measures the active power of the connected equipment. The two variants "earthing pin contact" and "IEC 320 socket C13" provide the most commonly used plug-in contacts in data centres. The 482.6 mm (19") long socket strip may optionally be mounted on the 482.6 mm (19") mounting angles, on the enclosure frame or in the rear section of wall-mounted distributors. The installation bracket may be mounted in four different positions for variable mounting. Without additional mounting accessories, the socket strip may be inserted into all sections with a 25 mm pitch pattern.



Material:

Aluminium section: Natural anodised
 Socket inserts: Polycarbonate

Supply includes:

Socket strip with two installation brackets including assembly parts,
 1.5 m connection cable with open ends.

Technical specifications:

Mains voltage: 250 V
 Rated current: 10/16 A, C13 earthing-pin
 Connection cable: 1.5 m

Design	No. of sockets	Attachment			Length mm	Mounting dimensions mm ¹⁾	Model No. DK
		Frame	Wall-mounted distributor, horizontal	482.6 mm (19") level			
Earthing-pin socket	6	■	■	■	482.6	452.5	7240.300
C13 IEC 320 socket	8	■	■	■	482.6	452.5	7240.305

¹⁾ Variable attachment distance within a range of 25 mm, the distance given is hole centre – hole centre of mounting bracket.

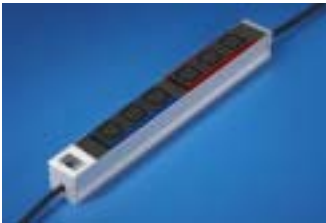

Socket strips With C13/19 sockets

Detailed information, see Cat. 31, page 746.

Design	No. of sockets	Attachment			Length mm	Mounting dimensions mm ¹⁾	Model No. DK
		Frame	Wall-mounted distributor, horizontal	482.6 mm (19") level			
C13 IEC 320 socket	15	■			592.6	562.5	7240.130
C13 IEC 320 socket with RC protection	15	■			724.6	694.5	7240.140
C13 IEC 320 socket with 2 ²⁾ infeeds	9 + 9	■			764.6	734.5	7240.150
C19 IEC 320 socket	6	■	■	■	452.5	482.6	7240.160
C19 IEC 320 socket with overvoltage protection device	4	■	■	■	452.5	482.6	7240.170
C19 IEC 320 socket with RC protection	4	■	■	■	452.5	482.6	7240.180
C19 IEC 320 socket with 2 ²⁾ infeeds	3 + 3	■	■	■	448.5	478.6	7240.190

All socket strips may also be ordered with a Wieland GST infeed.

¹⁾ Variable attachment distance within a range of 25 mm, the distance given is hole centre – hole centre of mounting bracket.

²⁾ In order to make allowance for the higher output density e.g. in an IT environment, the socket strips are equipped with 2 independent infeeds. This means it is possible to supply 2 x 16 A/250 V with one socket strip.

DK 7240.130

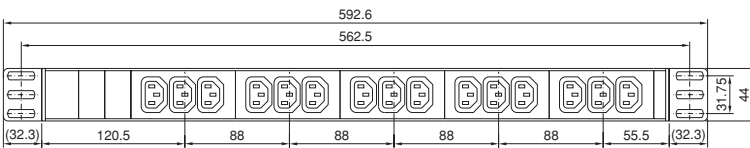

DK 7240.140

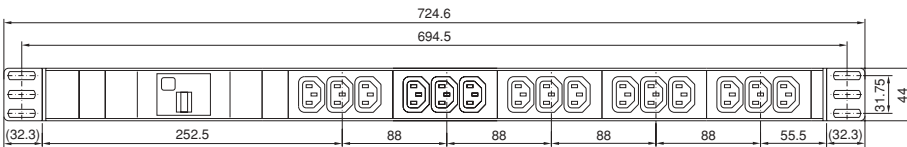

DK 7240.150

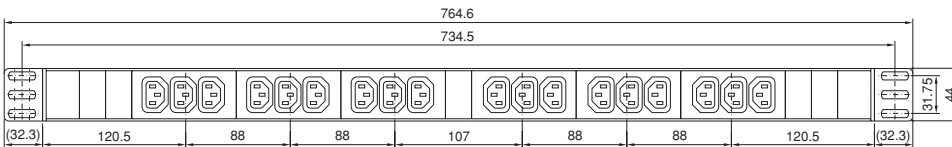

DK 7240.160

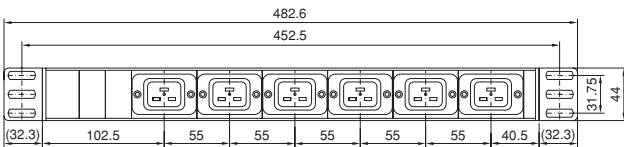

DK 7240.170

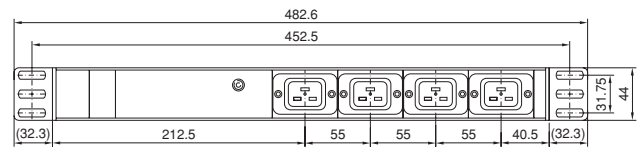

DK 7240.180

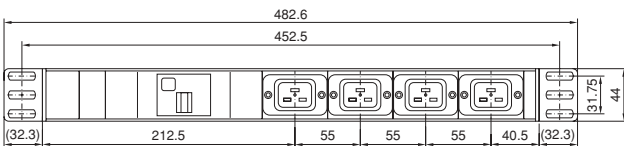

DK 7240.190

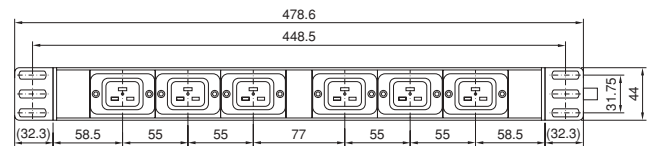

List of model numbers

Model No.	Page	Model No.	Page	Model No.	Page
2102.190	35	7320.530	25	7825.384	30
2102.410	35	7320.535	21	7825.385	30
2102.490	35	7320.585	20	7825.386	30
3301.430	35	7320.631	24	7825.387	32
3301.440	35	7320.640	24	7825.612	30
3301.800	16	7337.440	12	7825.622	31
7000.504	4	7337.445	12	7825.812	30
7000.508	4	7337.450	12	7826.362	35
7000.564	4	7337.455	12	7826.382	35
7000.568	4	7337.460	12	7827.544	35
7000.625	39	7337.465	12	7830.260	5
7000.686	29	7337.470	12	7831.489	10
7000.687	29	7337.475	12	7831.499	10
7000.690	29	7338.100	25	7831.580	10
7000.691	29	7338.200	25	7831.590	10
7000.692	29	7338.310	25	7856.027	15
7000.693	29	7493.100	32	7856.030	15
7000.694	29	7493.210	32	7856.203	13
7000.695	29	7493.230	32	7856.204	13
7000.696	29	7507.000	8	7856.321	13
7000.698	29	7507.010	8	7856.323	13
7000.940	6	7507.020	8	7857.130	15
7000.942	6	7507.030	8	7857.150	15
7000.944	6	7507.100	8	7857.180	15
7000.946	6	7507.110	8	7857.190	15
7000.960	6	7507.120	8	7857.325	13
7000.962	6	7507.200	8	7857.372	15
7016.140	37	7507.210	8	7857.420	15
7016.150	37	7507.220	8	7857.421	15
7063.200	38	7507.706	9	7857.430	14
7063.883	15	7507.709	9	7857.431	14
7111.214	36	7507.712	9	7857.432	14
7111.224	36	7507.715	9	7857.433	14
7111.300	37	7507.718	9	7857.434	14
7111.310	37	7507.721	9	7857.435	15
7111.350	38	7507.740	9	7857.436	15
7111.460	37	7507.760	9	7857.437	15
7111.480	37	7526.755	31	7857.439	15
7119.400	22	7526.795	31	7857.440	15
7151.105	38	7552.421	28	7857.441	15
7200.210	19, 25	7552.422	28	7857.442	15
7240.130	41	7555.100	27	7857.443	15
7240.140	41	7555.200	27	7857.444	15
7240.150	41	7555.300	27	7857.445	15
7240.160	41	7709.535	5	7886.000	35
7240.170	41	7715.535	5	7886.100	35
7240.180	41	7721.535	5	7886.200	35
7240.190	41	7824.124	33	7950.150	34
7240.300	40	7824.127	33	7950.200	34
7240.305	40	7824.600	33	8800.950	33
7240.600	40	7824.610	33	8801.920	34
7280.100	39	7824.850	38		
7320.005	22	7825.341	29		
7320.100	19, 23	7825.342	29		
7320.240	19	7825.343	29		
7320.241	19	7825.344	29		
7320.242	20	7825.345	29		
7320.245	20	7825.350	31		
7320.425	19	7825.363	30		
7320.440	19	7825.364	30		
7320.450	19	7825.365	30		
7320.470	19	7825.366	30		
7320.472	19	7825.367	32		
7320.481	19	7825.375	36		
7320.505	21	7825.382	30		
7320.515	21	7825.383	30		

We reserve the right to further developments and technical modifications of our products. Such modifications, along with errors and printing errata, shall not constitute grounds for compensation. We refer customers to our Terms of Sale and Delivery.

A

Active PSM 6-way	13
Aisle cover for server racks	35
Alternate frame, magnetic	34
Attachment of the CMC-TC Master II	22

B

Base frame, divided	29
Base module for cable entry	32
Base/plinth trim, solid	29
Base/plinth, vented, for TE 7000	29
Blanking panel 1 U	38
Brush strip	
– super-airtight	36
– vertical	35
Busbar PSM	13

C

Cable clamp, variable	37
Cable deflector	
– for 482.6 mm (19") mounting angles	37
Cable routing bars	
– for 482.6 mm (19") system punchings	36
Cable routing, snap-in CMC-TC	37
– Acoustic sensor	24
– Leak sensor, 15 m	24
– Monitoring system Processing Unit II (PU II)	23
– Wireless sensor network	17 – 21
Component shelf, pull-out, complete set for TE 7000	39
Cooling unit roof-mounted	16
Cover plates for fan panels	9
Cover section	38

D

Designer handle	33
Distributor frame TE 7000 open	6
Document clip, magnetic	34
Drawer 482.6 mm (19") – to accommodate excess cable length	38

E

EL wall-mounted enclosure	5
External aerial	19

F

Fan roof, modular, two-piece – for TS	35
FlatBox	7 – 9

G

Gland plate	
– multi-piece	30
– one-piece	30
Gland plate modules, vented	30

H

Hinges 180°, for TS	33
---------------------	----

I

IP protective cover	20
---------------------	----

L

Levelling feet	
– for FlatBox	9
– with hex socket	32
– with vibration dampening	32

M

Module plate, solid	
– for TE	31
Monitoring system – CMC-TC Master II	22
Mounting adaptor	33
Mounting angles for FlatBox	9

N

Network enclosures	
– Based on Rittal TE 7000, metric attachment level	4
– Based on Rittal TS 8, pre-configured	5
– TE 7000 open	6
Nylon loop cable holder, self-adhesive	38

P

PDM socket strip	13
Processing Unit II (PU II)	23
PSM busbar	13

R

Rack extinguisher system	25
Rittal network video monitoring	26
RiWatchIT	27
Roof plates DK-TS	34
Roof-mounted cooling unit	16

S

Server racks	
– Based on Rittal TS 8, pre-configured	10
– Smart Package, pre-configured	11 – 12
Service socket	39
Sheet steel door, vertically divided – for TS	33
Smart Package	11 – 12
Snap-in cable routing – for clipping into the system punchings	37
Socket strips	
– 482.6 mm (19")	40
– PDM	13
– with ammeter	40
– with C13/19 sockets	41
Spare filter mat	31
SSC Connect	28
Sub-distributor 482.6 mm (19") UPS, modular	15

T

TE 7000	
– metric attachment level	4
– open, distributor frame	6

U

UPS, single-phase	14 – 15
-------------------	---------

V

Video monitoring	26
------------------	----

W

Wall-mounted enclosures	
– Based on Rittal EL, pre-configured	5
Wireless	
– Access sensor	21
– Digital input	20
– Humidity sensor	21
– I/O Unit	19
– Measurement system	20
– Sensor network	17 – 21
– Temperature sensor	21

All in all – solutions from Rittal



Industrial Enclosures



Power Distribution



Electronic Packaging



System Climate Control



IT Solutions

Network enclosures · Server racks · KVM technology
Telco racks · Office solutions · Distributor racks
Wall-mounted enclosures · RimatriX5 · Power management
concepts · IT cooling · Monitoring · Security · Services · Kiosks



Communication Systems

Rittal has one of the largest ranges of enclosures available for immediate delivery. However, Rittal also supplies integrated solutions – up to Level 4. This comprises mechanical installation, power supply, electronic components, climate control and central monitoring. For all of your requirements.

Fully assembled and functional. Wherever in the world you develop and implement solutions for yourself and your customers, we are close at hand. The global alliance between production, distribution and service guarantees closeness to the customer. Worldwide!

05/07 · E572

